



Performance Analyzing of an Inverted Absorber Basin Solar Still Equipped with Photovoltaic Cells

M. Karimi Takaloo, F. Sarhaddi*, F. Sobhnamayan

Department of Mechanical Engineering, University of Sistan and Baluchestan, Zahedan, Iran

ABSTRACT: In the present paper, a basin solar still with a curved inverted reflector under the basin is studied. In the investigated solar still, some photovoltaic cells are inserted on the glass cover of the condenser. Therefore, the system produces fresh water and electricity, simultaneously. By writing energy balance for different components of the system, photovoltaic cells temperature, condenser glass cover temperature, water temperature, and absorber temperature can be obtained. Also, the thermal and electrical efficiencies of the system are introduced. Present study simulation results are consistent with experimental data of the previous studies. Parametric study results show that increased water depth reduces freshwater productivity and its effect on the electricity production is negligible. Increasing photovoltaic cells reduces freshwater productivity and raises electricity production. Increased wind velocity and increase in the basin area increase freshwater productivity and electricity production. Also, an increase in the number of photovoltaic cells increases the electrical efficiency and reduces thermal efficiency, therefore, it decreases system overall efficiency. Water depth effect on electrical efficiency is negligible but, it decreases thermal efficiency and the overall efficiency of the system.

Review History:

Received:
Revised:
Accepted:
Available Online:

Keywords:

Basin solar still
Inverted absorber
Photovoltaic cells
Energy analysis

1. INTRODUCTION

About three percent of the water resources available on the earth are potable [1]. In most countries of the world, including Iran, freshwater scarcity has become a serious problem. Regarding the rising cost of fossil fuels, with the reduction of its resources and the pollution caused by its untapped use, renewable energy has been considered. Therefore, given the fact that the Persian Gulf states, including Iran, enjoy the high potential for solar energy, interest in solar still systems has emerged. In 2015, El-Sebaï et al. [2] examined the effect of fin's connection to the absorber plate on the performance of the basin solar still. They reported that the production of fresh water with a thickness of fins and a height of fins had a direct and indirect relation, respectively. The excessive increase in fins and, consequently, the increase in the shade of fins, reduce the production of water. They reported that, in the best case with fins, fresh water production was 13.7 percent higher than usual.

The novelty of the paper is the presence of photovoltaic cells on the condenser glass cover and the correction of photovoltaic cells electrical model. In the past [1-4], simple and inverted absorber solar still have been investigated. But, in the present paper, the performance of an inverted absorber solar still equipped with photovoltaic cells has been investigated. In this case, in addition to fresh water production, electricity will be produced at the same time.

2. GOVERNING EQUATIONS OF PROBLEM

In the present study, a basin solar still system with a

*Corresponding author's email: fsarhaddi@eng.usb.ac.ir

curved inverted reflector under the basin is studied. In the mentioned solar still, the water in the basin will be heated from both up and down. Also, with using the photovoltaic cells on the condenser glass cover, electricity is produced in addition to the water production. Fig. 1 shows a schematic diagram of the study system. Energy balance equations for various components of the solar still have been written for the performance analysis and the simulation of the inverted absorber solar still, equipped with photovoltaic cells. A nonlinear ordinary algebraic differential equation is obtained to find the temperature of the various components of the system. A simulation code has been developed in MATLAB

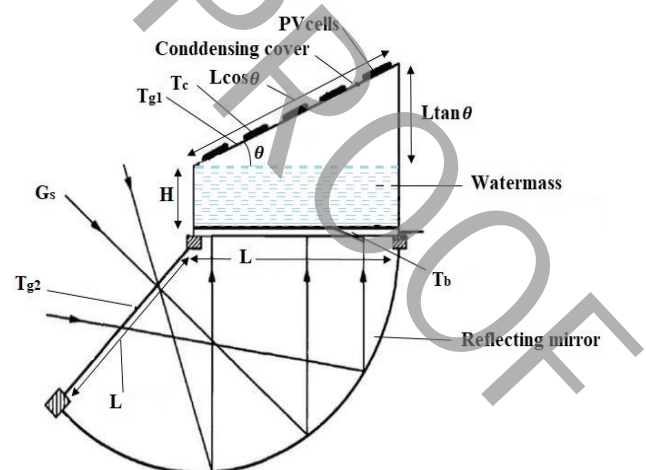

Fig. 1: Schematic diagram of the studied system

software in order to simulate the system and carry out parametric studies. Energy balance for photovoltaic cells, the condenser glass cover, the absorber plate and water in the basin can be seen in Eqs. (1) to (4), respectively [1-4].

$$\alpha_c G_s \beta_c A_{g1} = h_{ca} \beta_c A_{g1} (T_c - T_a) + \beta_c A_{g1} \eta_{el} G_s + h_{cg1} \beta_c A_{g1} (T_c - T_{g1}) \quad (1)$$

$$\alpha_{g1} (1 - \beta_c) A_{g1} G_s + h_{wg1} A_b (T_w - T_{g1}) + h_{cg1} \beta_c A_{g1} (T_c - T_{g1}) = h_{g1a} (1 - \beta_c) A_{g1} (T_{g1} - T_a) \quad (2)$$

$$\tau_{g1} \tau_w \alpha_b (1 - \beta_c) A_{g1} G_s + \tau_{g2} r_{inv}^N \alpha_b A_{g2} G_s = h_{bw} A_b (T_b - T_w) + h_{ba} A_b (T_b - T_a) \quad (3)$$

$$\tau_{g1} \tau_w (1 - \beta_c) A_{g1} G_s + h_{bw} A_b (T_b - T_w) = M_w c_w \frac{dT_w}{dt} + h_{wg1} A_b (T_w - T_{g1}) + h_{wa} A_s (T_w - T_a) \quad (4)$$

The evaporative energy of the solar still and the amount of fresh water produced by the system are obtained as follows in Eqs. (5) and (6), respectively.

$$\dot{q}_{ev} = h_{ev} A_b (T_w - T_g) \quad (5)$$

$$m_w = \frac{\dot{q}_{ev} \Delta t}{h_{fg}} \quad (6)$$

Finally, the thermal efficiency of the system is obtained by Eq. (7).

$$\eta_{th} = \frac{\dot{q}_{ev}}{A_g \times G_s} \quad (7)$$

3. VALIDATION

Regarding the governing equations of the inverted absorber solar still, a MATLAB simulation code is developed. The simulation results of this code are validated with the results of Tiwari et al. [5] and are presented in Table 1.

According to Table 1, the present study simulation results are in good agreement with experimental data of Tiwari et al. [5].

4. RESULTS

Fig. 2 shows the diagram of the changes in thermal efficiency, electrical efficiency, and total system efficiency,

Table 1: Validation the results of this research

Parameter	Error percent (%)
Water temperature (T_w)	5.50
Absorber plate temperature (T_b)	4.33
Condenser glass temperature (T_{g1})	6.41
Freshwater production (m_w)	0.979

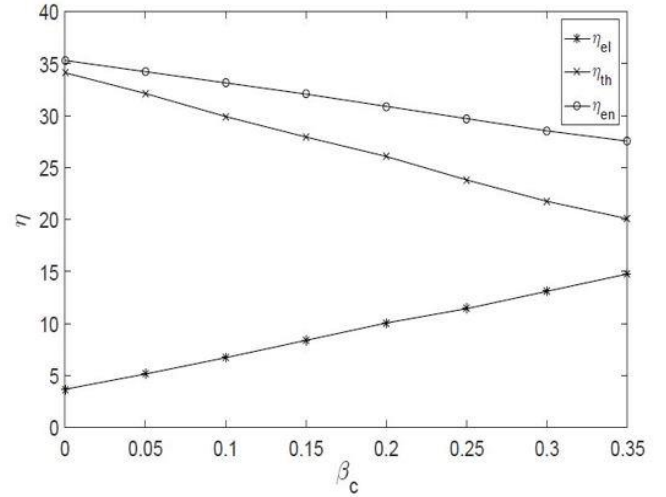

Fig. 2: Efficiency of the system in terms of the percentage of coating of the surface of the glass cover by photovoltaic cells

based on changes in the percentage of surface coverage by photovoltaic cells and for optimal parameters.

According to Fig. 2, with the increase of photovoltaic cells, the electrical efficiency increases and thermal efficiency decreases. As the photovoltaic cells increase, electricity production increases and fresh water production decreases, and in general, the overall system efficiency decreases.

5. CONCLUSIONS

Main conclusions of the present study are as follows:

- The simulation results of this study are in good agreement with the experimental results of previous studies.
- Increase of photovoltaic cells increases the electrical efficiency and reduces the thermal efficiency, so it decreases system overall efficiency.

REFERENCES

- [1] Velmurugan, V., Gopalakrishnan, M., Raghu, R., Srithar, K., 2008. "Single basin solar still with fin for enhancing productivity", *Energy Conversion and Management*, 49, pp. 2602-2608.
- [2] El-Sebaei, A.A., Ramadan, M.R.I., Aboul-Enein, S., El-Naggar, M., 2015. "Effect of fin configuration parameters on single basin solar still performance", *Desalination*, 365, pp. 15-24.
- [3] Afrand, M., Kalbasi, R., Karimipour, A., Wongwises, S., 2016. "Experimental investigation on a thermal model for a basin solar still with an external reflector", *Energies*, 10, pp. 1-18.
- [4] Omara, Z.M., Abdullah, A.S., Dakroryc, T., 2017. "Improving the productivity of solar still by using water fan and wind turbine", *Solar Energy*, 147, pp. 181-188.
- [5] Dev, R., Sabah, A., Abdul-Wahab, Tiwari, G.N., 2011. "Performance study of the inverted absorber solar still with water depth and total dissolved solid", *Applied Energy*, 88, pp. 252-264.