



Parametric Analysis and Optimization of a Trigeneration System Based on the Tubular Solid Oxide Fuel Cell

N. Aghazadeh, S. Khalilarya, S. Jafarmadar, A. Chitsaz*

Department of Mechanical Engineering, Urmia University, Urmia, Iran

ABSTRACT: In this article, a new power, cooling and heating trigeneration system consisting of a hydrogen-fed solid oxide fuel cell-gas turbine, a heat recovery steam generator, generator-absorber-heat exchange absorption refrigeration cycle, and a heat exchanger for heat recovery has been studied from a parametric and optimization perspective. In contrast with most of the previous investigations, in which the heat recovery steam generator is located at the downstream of generator-absorber-heat exchange, in the present research, in order to control the wasted heat, heat recovery steam generator is located at the upstream of generator-absorber-heat exchange, and then, the wasted heat at the system output is used at the heat exchanger for heat recovery. Due to the important role of the fuel cell in the introduced system, the electrochemical analysis is complete for the fuel cell and the cell temperature is computed for all the working conditions of the cell. Then, the parametric study of the trigeneration system, the influences of current density, fuel utilization factor, compressor pressure ratio and air utilization factor on the performance of the system are investigated. After a parametric study, the optimization of the system is performed in the method of the genetic algorithm to determine the optimal functional points. After optimization and exergoeconomic analysis, the minimum sum of the unit costs of products, the exergy destruction cost rate and the exergoeconomic factor for the overall system is equal to 277.2 \$/GJ, 40.8 \$/h and 27.8%, respectively. Therefore, the increase in the components' capital costs can improve the exergoeconomic performance of the system.

Review History:

Received:
Revised:
Accepted:
Available Online:

Keywords:

Tubular solid oxide fuel cell
Trigeneration
Heat recovery steam generator
Exergoeconomic
Optimization

1. INTRODUCTION

Nowadays, the use of hybrid systems for trigeneration is considered one of the essential ways to reduce energy consumption and environmental pollution. In the trigeneration plant, supplementary power, heating, and cooling are recovered from the waste heat as the subsidiary product of power generation. In this regard, trigeneration systems based on Solid Oxide Fuel Cell (SOFC) have the highest efficiency, due to the high operating temperature and the combination of the gas turbine. The waste heat of these systems can be used to generate heating in the heat recovery steam generator and cooling in absorption refrigeration cycles. In recent years, many researchers have investigated trigeneration cycles and the use of solid oxide fuel cell as the prime mover of these systems [1-3].

According to previous studies and the essentials of using trigeneration systems in the power plant, a novel trigeneration system based on tubular SOFC is proposed and the wasted heat in the Heat Recovery Steam Generator (HRSG) and a Generator-Absorber-Heat Exchange (GAX) absorption refrigeration cycle and a heat exchanger for Heat Recovery (HR) is used. Our purpose in this paper is parametric study and exergoeconomic analysis and optimization of the proposed trigeneration system.

*Corresponding author's email: a.chitsaz @urmia.ac.ir

2. METHODOLOGY

The proposed trigeneration system is shown in Fig. 1. Fuel used in the systems contains 89% H₂ and 11% H₂O

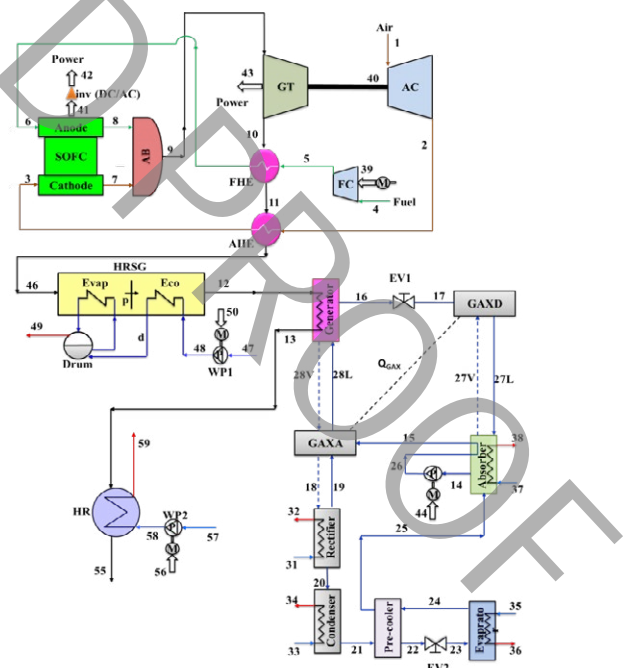

Fig. 1: Schematic diagram of the trigeneration system

and air contains 21 % oxygen gas and 79 % nitrogen gas. The main part of this system is the solid oxide fuel cell in which the electrochemical reaction $H_2+0.5O_2 \rightarrow H_2O$ takes place. Following assumptions are considered for the system modeling [2, 4]:

- The system operates under steady state condition.
- Kinetic and potential energy changes are neglected.
- SOFC-gas turbine cycle components are adiabatic.
- Gases in the SOFC-gas turbine cycle are ideal gases.
- Anode and cathode outlet temperatures are the same.
- Pressure drops due to friction are neglected only in the GAX cycle.

The electrochemical equations for the fuel cell and exergy balance equations and the governing equations applied at each component of the proposed trigeneration system can be found in Ref.[5]. To calculate the exergy unit cost of each stream, the cost balance equation along with the required auxiliary equations are applied to each system component. For a system component receiving heat and producing power, the cost balance is written as [6]:

$$\sum_e (\dot{C}_{e,k}) + \dot{C}_{w,k} = \dot{C}_{q,k} + \sum_f (\dot{C}_{f,k}) + \dot{Z}_k \quad (1)$$

$$\dot{C} = c\dot{E} \quad (2)$$

The total irreversibility rate, the net electrical output power, exergy efficiency and Sum of the Unit Costs of the Products (SUCP) are used to assess the trigeneration system performance:

$$\dot{E}_{D,tot} = \sum_k \dot{E}_{D,k} + \dot{E}_{55} \quad (3)$$

$$\dot{W}_{net} = (\dot{W}_{SOFC})\eta_{mv} - \dot{W}_{AC} - \dot{W}_{FC} - \dot{W}_P - \dot{W}_{WP1} - \dot{W}_{WP2} \quad (4)$$

$$\psi = \frac{\dot{W}_{net} + (\dot{E}_{36} - \dot{E}_{35}) + (\dot{E}_{49} - \dot{E}_{48}) + (\dot{E}_{59} - \dot{E}_{58})}{\dot{n}_f \bar{e}_f} \quad (5)$$

$$SUCP = C_{36} + C_{42} + C_{43} + C_{49} + C_{59} \quad (6)$$

3. RESULTS

In this section, the parametric study of the trigeneration system, the effect of current density, fuel utilization factor, compressor pressure ratio and air utilization factor on the performance of the system are investigated. The variations in the exergy efficiency with the pressure ratio are shown in Fig. 2 for two values of air utilization factor. It is observed that the exergy efficiency decreases as pressure ratio increases. Also, higher exergy efficiency is obtained with a higher air utilization factor. The effect of current density and fuel utilization factor on the total irreversibility rate and SUCP is presented in Fig. 3. The total irreversibility rate is observed to increase and the SUCP decreases with increasing current density. In addition, the total irreversibility rate is lower and SUCP is higher for a higher fuel utilization factor.

According to the results of the optimization and exergoeconomic analysis, minimum SUCP, the exergy destruction cost rate and exergoeconomic factor for the overall system is equal to 277.2 \$/GJ, 40.8 \$/h and 27.8%, respectively. Therefore, the increase in the components'

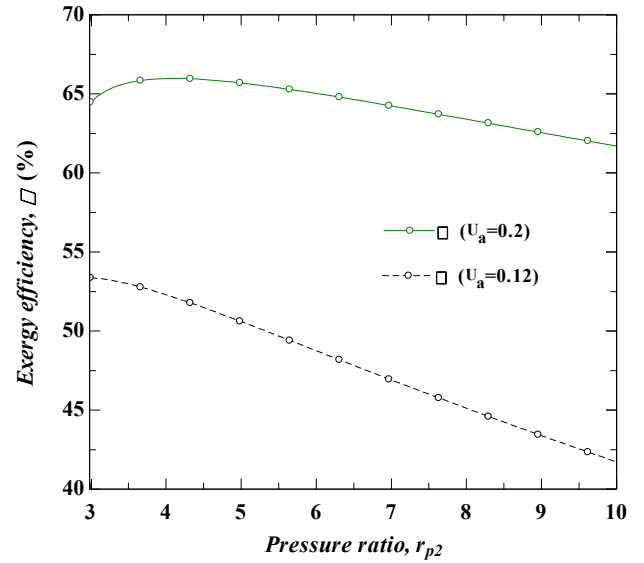

Fig. 2: Effect of pressure ratio and air utilization factor on exergy efficiency

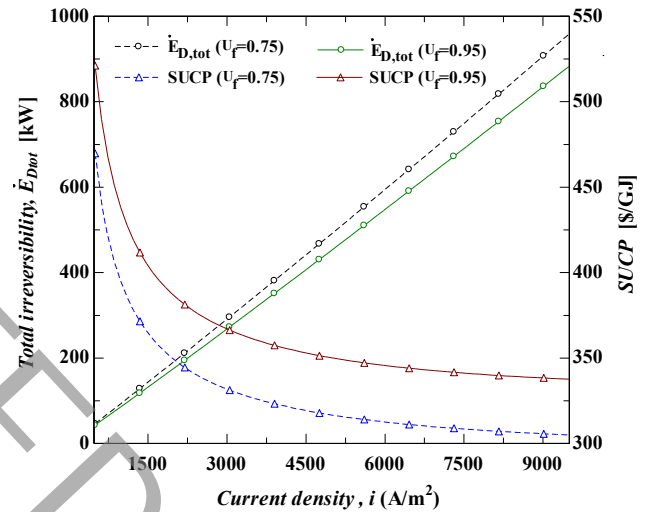

Fig. 3: Effect of current density and fuel utilization factor on the total irreversibility and SUCP

capital costs can improve the exergoeconomic performance of the system.

4. CONCLUSIONS

In this paper, a novel trigeneration system based on a solid oxide fuel cell and gas turbine with hydrogen fuel is proposed and analyzed parametrically. Then, it was optimized from the perspective of exergoeconomic and ultimately the exergoeconomic analysis was performed on the optimized system. The main conclusions that can be drawn from the principal findings of the present work are as follows:

- The afterburner and the fuel heat exchanger have the lowest exergoeconomic factors, based on the exergoeconomic analysis, suggesting that their exergy efficiencies should be increased.
- Minimum SUCP calculated the optimization from the exergoeconomic perspective to be 277.2 \$/GJ.

REFERENCES

- [1] A.V. Akkaya, B. Sahin, H.H. Erdem, An analysis of SOFC/ GT CHP system based on exergetic performance criteria, *International Journal of Hydrogen Energy*, 33(10) (2008) 2566-2577.
- [2] L. Khani, S.M.S. Mahmoudi, A. Chitsaz, M.A. Rosen, Energy and exergoeconomic evaluation of a new power/cooling cogeneration system based on a solid oxide fuel cell, *Energy*, 94 (2016) 64-77.
- [3] F. Ranjbar, A. Chitsaz, S. Mahmoudi, S. Khalilarya, M.A. Rosen, Energy and exergy assessments of a novel trigeneration system based on a solid oxide fuel cell, *Energy Conversion and Management*, 87 (2014) 318-327.
- [4] A.V. Akkaya, B. Sahin, H.H. Erdem, Exergetic performance coefficient analysis of a simple fuel cell system, *International Journal of Hydrogen Energy*, 32(17) (2007) 4600-4609.
- [5] N. Aghazadeh, S. Khalilarya, S. Jafarmadar, A. Chitsaz, Thermoeconomic analysis of a novel trigeneration system based on solid oxide fuel cell and gas turbine with hydrogen fuel, *Modares Mechanical Engineering*, 18(4) (2018) 883-894. (in Persian).
- [6] A. Bejan, G. Tsatsaronis, *Thermal design and optimization*, John Wiley & Sons, 1996.