



Modelling and Experimental Investigation of the Evaporation Suppression Using Floating Covers in the Presence of Surface Flows

A. Rezazadeh¹, P. Akbarzadeh^{1*}, M. Aminzadeh²

¹ Department of Mechanical and Mechatronics Engineering, Shahrood University of Technology, Shahrood, Iran

² Department of Civil Engineering, Isfahan University of Technology, Isfahan, Iran

ABSTRACT: Today, preserving fresh-water is important because of population growth, climate change, and droughts. In arid regions, a significant part of stored-water is destroyed due to evaporation, in which the coverage of the reservoirs with floating elements is a simple and reliable technique to reduce evaporation. Despite numerous studies on the application of floating elements, the performance of this method in the presence of surface flows is not yet addressed comprehensively. Hence, the present study aims to investigate the effect of surface flows on evaporation from covered reservoirs. For this purpose, white and black balls for covering the reservoir and a water-pump provided surface flows were used. The results show that the evaporation rate decreases to a specific surface flow (optimal value), and increases again with increasing the flow. Also, the lowest water evaporation occurs for the coverage with white balls while coverage using a mixture of black and white balls and only with black balls showed higher evaporation rates, respectively (the highest evaporation is also for the uncovered surface). Also, the results of energy modeling show that the governing equations for the modeling have reasonable accuracy in estimating the evaporation rate for all uncovered/covered and with/without surface flow conditions.

Review History:

Received:

Revised:

Accepted:

Available Online:

Keywords:

Surface water evaporation

Surface flows

Floating balls

Optimal flow rate

Energy balance

1. INTRODUCTION

Freshwater supply is one of the major concerns in many parts of the world due to increasing droughts, reducing rainfall, and the progress of human society, population growth, and development of the industry. So, many countries are trying to optimize their consumption and reduce their losses with different strategies. One of these strategies is reducing water evaporation which is carried out in a variety of ways such as the use of floating physical covers [1], windbreaks [2], and chemical coatings [3]. Aminzadeh et al. [1] used polyethylene balls and styrofoam discs in white and black colors as floating covers on opening reservoirs. Their results showed that the discs have a better performance than floating balls in reducing evaporation. Another attractive result of their study was the lack of effect of covers color on evaporation reduction efficiency due to the thermal properties of the covers. In addition to conducting empirical studies, there are a lot of relationships to estimate the approximate evaporation rate from lakes, dams, and other water reservoirs based on an energy balance analysis on the water surface. One of the most commonly used relationships is the Penman-Monteith, Prestley Taylor, and mass transfer which requires different parameters for using each of these relationships. In most studies, these relationships have been used to evaluate surface evaporation rates, regardless of the surface flow effects such as Masoner and Stannard [4]. While many

water reservoirs have inlet and outlet surface flows, these flows cause the thermal mixing between layers and affect the evaporation rate [5]. Therefore, the main objective of the present study is modelling and experimental investigation of the evaporation suppression using floating covers in the presence of surface flows.

2. METHODOLOGY

This experiment was conducted at the Energy Specialty Laboratory of the Shahrood University of Technology. Fig. 1 shows the schematic drawing of the equipment and the experiment structure. A polyethylene reservoir with $106 \times 107 \times 50$ cubic meters dimensions and 6 mm wall thickness was used to store the water. A pump was used to create surface flow-rates. A pressure transmitter in the bottom of the Mariott bottle was recorded the hydrostatic pressure changes. In order to measure air temperature, relative humidity, and wind speed a psychrometer-anemometer device (C310, KIMO: $\pm 0.1^\circ\text{C}$ & $\pm 1.5\% \text{FS-RH}$ & $\pm 3.05\% \text{FS-Vel}$ accuracy) was utilized. The water temperature was measured by four thermocouples (KTT320, KIMO: $\pm 0.1^\circ\text{C}$ accuracy) at depths of 0, 12, 24 and 36 cm from the water surface. Humidity and velocity sensors were installed at a height of 30 cm from the water surface. Six 500 watts of lamps, with uniform radiation of 600 to 700 watts per square meter, acted as a sun simulator on the entire surface of the reservoir (the tungsten-halogen spectrum is similar to the sunlight with a peak of $0.9 \mu\text{m}$ at 3200 Kelvin). A pyranometer (SL100 KIMO: 0~1300 W/

*Corresponding author's email: akbarzad@ut.ac.ir;
p.akbarzadeh@shahroodut.ac.ir



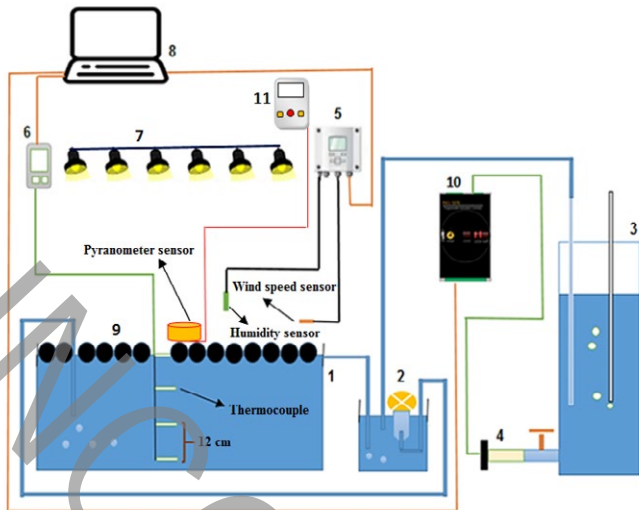

Fig. 1. Schematic drawing of the equipment and the experiment structure: (1) Polyethylene reservoir, (2) Pump, (3) Mariott bottle, (4) Pressure transmitter, (5) Psychrometer and Anemometer device, (6) Thermometer, (7) Lamps, (8) Monitor for displaying and storing measured values, (9) Floating covers, (10) Pressure recording and processing device, (11) Pyranometer.

m^2 , $\pm 0.5 \text{ W/m}^2$ accuracy) was used to measure the amount of radiation applied on the surface of the reservoir.

3. RESULTS AND DISCUSSION

Seven different surface water flow rates including 1, 3, 4.5, 6.5, 8, 10, and 12 liters per minute created by the pump were tested. In each flow rate, evaporation of no-cover, covered with white balls, covered with black balls, and combined coverings (in the form of an equal mixture of black and white balls) conditions were measured for a period of six hours. As seen in Fig. 2, floating balls have a significant effect on reducing evaporation. In addition, by increasing the flow rate and consequently increasing the mixing of the epilimnion and hypolimnion layers, the evaporation will decrease until an optimum flow rate. For example, for no-cover condition, the rate of evaporation decreases from 0.915 mm/hr (when there is no flow rate) to about 0.685 mm/hr when the flow rate is about 6.5 liters per minute (as the optimum flow rate). Then the evaporation increases by passing the flow rate from the optimum value. To analyze this phenomenon, it is necessary to provide further explanations for the boundary layer of air created on the reservoir surface. By creating a water surface flow, the air layer on the reservoir is forced to move due to the no-slip boundary condition and the aerodynamic boundary layer forms by a thickness δ_v . Since the value of δ_v is proportional to the inverse of the air velocity near the surface [6], increasing the surface flow rate results in decreasing the value of δ_v and the thickness of the mass transfer boundary layer i.e. $\delta_m = Sc^{-1/3} \delta_v$ (where Sc is Schmidt number) [6, 7]. As a result, the gradient of vapor concentration increases between the surface and air flow, and eventually the evaporation rate increases. Also, according to the results of Aminzadeh and Or [7] and Haqiqi and Or [8], the sensible heat flux coefficient is

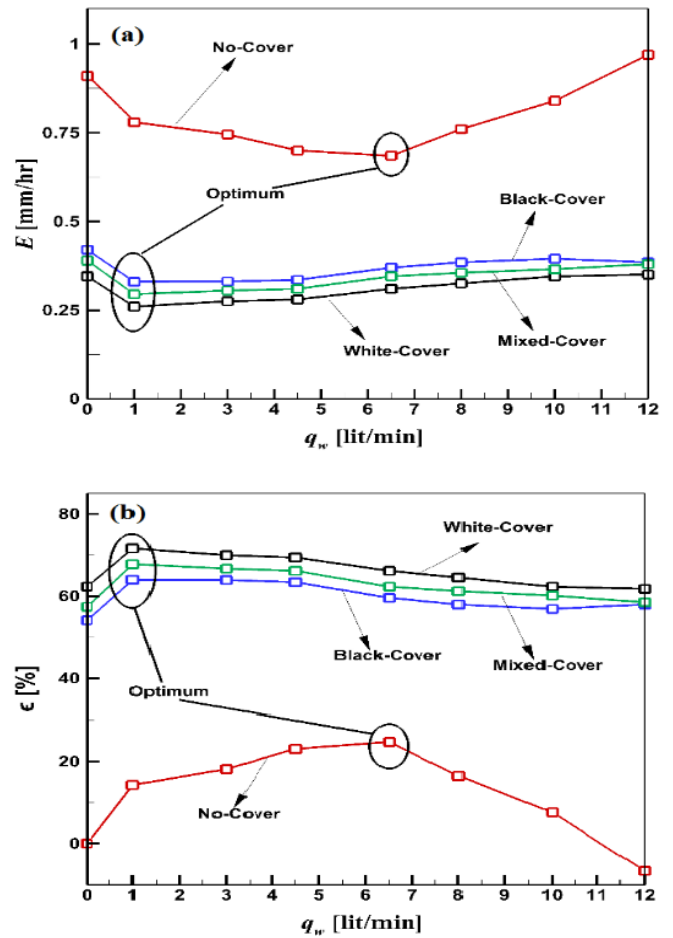

Fig. 2. Results obtained by the surface evaporation test for various surface flow-rate. (a) Surface evaporation for the last two hours from total of six hours of experiment time (b) Evaporation reduction efficiency. Here the evaporation from no-cover surfaces in no-flow condition (i.e., $E_0 = 0.915 [\text{mm/hr}]$) is used as the reference evaporation to calculate the efficiency.

proportional to the thickness of the boundary layer. Thus, by increasing the surface flow-rate, the heat transfer between the water surface and the air is increased for a condition where the surface temperature is lower than the air temperature (often in summers). In this way, the energy needed to increase the evaporation rate is provided. Therefore, by passing the optimal flow-rate, the role of increasing the evaporation rate due to the reduction of the thickness of the boundary layer exceeds from the role of the mixing of the water layers in reducing the evaporation rate and it reduces the evaporation efficiency.

4. CONCLUSION

The present study focuses experimentally on the effect of surface flows on evaporation from covered reservoirs. For this purpose, a water reservoir was covered with white and black balls and a water-pump provided surface flows at different rates (i.e. 1, 3, 4.5, 6.5, 8, 10, and 12 liters per minute). The results show that in the presence of surface flows evaporation

decreases to a specified rate, called optimal-flow-rate, and then increases with increasing the flow rate from the optimal case. Regardless of surface flow condition, the results indicate that the lowest water evaporation occurs for the coverage with white balls while coverage using a mixture of black and white balls and only with black balls showed higher evaporation rates, respectively (the highest evaporation is also for the uncovered surface).

REFERENCES

- [1] M. Aminzadeh, P. Lehmann, D. Or, Evaporation suppression and energy balance of water reservoirs covered with self-assembling floating elements, *Hydrology and Earth System Sciences*, 22(7) (2018) 4015-4032.
- [2] F. Helfer, H. Zhang, C. Lemckert, Evaporation reduction by windbreaks: Overview, modelling and efficiency, *Urban Water Security Research Alliance Technical Report*, (16) (2010) 1-15.
- [3] P. Schouten, S. Putland, C.J. Lemckert, A.V. Parisi, N. Downs, Alternative methods for the reduction of evaporation: practical exercises for the science classroom, *Physics Education*, 47(2) (2012) 202-210.
- [4] J.R. Masoner, D.I. Stannard, A comparison of methods for estimating open-water evaporation in small wetlands, *Wetlands*, 30(3) (2010) 513-524.
- [5] M. Van Dijk, S. Van Vuuren, Destratification induced by bubble plumes as a means to reduce evaporation from open impoundments, *Water SA*, 35(2) (2009) 157-167.
- [6] E. Haghighi, D. Or, 2013. Evaporation from porous surfaces into turbulent airflows: coupling eddy characteristics with pore scale vapor diffusion, *Water Resources Research*, 49(12) (2003), 8432-8442.
- [7] M. Aminzadeh, D. Or, Energy partitioning dynamics of drying terrestrial surfaces, *Journal of Hydrology*, 519 (2014) 1257-1270.
- [8] E. Haghighi, D. Or, Interactions of bluff-body obstacles with turbulent airflows affecting evaporative fluxes from porous surfaces, *Journal of Hydrology*, 530 (2015) 103-116.