

Thermodynamic analysis of power generation system based on solid oxide fuel cell with external reforming

Moharram Jafari^{1*}, Mohsen Sadeghi², S.M.S. Mahmoudi³, Mortaza Yari⁴

¹ Assistant Professor, Faculty of Mechanical Engineering, University of Tabriz

² PhD Student, Faculty of Mechanical Engineering, University of Tabriz

^{3,4} Professor, Faculty of Mechanical Engineering, University of Tabriz

ABSTRACT

Due to the capability of using exhausted gases of power plants directly in reforming process and producing high quality syngas, the tri-reforming process is a considerable kind of reforming process. In the present study, a power generation system based on solid oxide fuel cell with specific capacity and equipped to the external reforming is proposed and investigated from the viewpoint of thermodynamics. In order to conduct the external reforming process, exhausted gases from the system including the steam, carbon dioxide and oxygen are recycled and utilized as the reforming agents in the reactor. In order to model the proposed system thermodynamically, the principals of mass and energy balance are applied in Engineering Equation Software (EES). Effects of such important parameters as the current density and solid oxide fuel cell operating temperature on the system performance indicators including the various voltages, fuel mass flow rate, power generation and the energy as well as the exergy efficiencies of the system are investigated. The parametric study results shows that for the lower values of the current density e.g. 1000 A/m² and higher values of the SOFC operating temperature e.g. 900 oC, the system energy and exergy efficiencies enhances up the maximum values of 55.04% and 53.11%, respectively.

KEYWORDS

Power generation system, solid oxide fuel cell, external reformer, hydrogen, thermodynamic analysis

*Corresponding author: mjafari@tabrizu.ac.ir

Introduction

Serious worries about decreasing the fossil fuels resources as well as their environmental impact e.g. global warming motivates researchers move forward to the more efficient power generation systems [1]. In this regard, solid oxide fuel cells (SOFC) with the capability of converting the fuel chemical energy directly into the electrical energy are as promising methods to produce the electricity in a green and efficient way. Considering the point that the SOFCs operate at high temperatures; they have high potential to integrate with the bottoming power generation cycles and processes e.g. gasification and reforming [2].

Dietrich et al. [3] investigated the effects of anode off gas recycling (AOGR) on the performance of a small scale propane driven SOFC system. They reported that the efficiency of the system with anode off gas recycling is improved. Saebea et al. [4] presented analyzed performance of an SOFC system coupled to an ethanol reforming process with anode off gas recycling. The results demonstrated that under the same thermodynamic conditions, anode EGR leads to an increase in electrical efficiency of the system. Faro et al. [5] analyzed performance of a biogas fed SOFC integrated with the tri-reforming process. They concluded that the proposed system is suitable for small sized power plants applications. Walluk et al [6] investigated the effects of auto-thermal reforming for SOFC systems with anode off-gas recirculation. It was found that for the optimal value of 45 % for AOGR, the maximum efficiency of reforming process is achieved. Mehr et al. [7] analyzed the a biogas fed solid oxide fuel cell power generation system with anode and cathode recycling thermodynamically and economically. The results revealed that comparing the simple system, the energy efficiency of the SOFC with anode and cathode recycling is improved up to 6.81%. Furthermore, they reported that the unit product cost of the system with anode and cathode recycling gets about 35% cheaper. A biogas fed solid oxide fuel cell based plant coupled to the external tri-reforming was proposed and simulated by Manenti et al. [8]. They investigated the influence of current density and reforming parameters on the cell potential behavior. A comprehensive investigation on the anode EGR in solid oxide fuel cell systems with various fuels was conducted by Rokni [9]. The results outlined, that the amount of EGR depends strongly on type of the fuel used in the system. A comparative study on the effects of using external reforming against internal reforming was performed by Chitsaz et al. [10]. The optimization results showed that the exergy efficiency of the system with internal reforming is about 9.6% higher than that of with external reforming.

Surveying the literature demonstrates that all the studies on the on the coupling of the SOFCs to the external reforming limits to the anode and/or cathode off gas recycling and there is no study on the chemical recuperation of the after burner exhausted gases. In this regard, the present work is an attempt to fulfill this lack of information and investigate the effects of chemical recuperation and tri-reforming on the performance of a SOFC based plant from the viewpoint of thermodynamics.

Methodology

Schematic of the proposed SOFC power generation system integrated with tri-reforming process through exhausted gas recycling is depicted in Fig. 1.

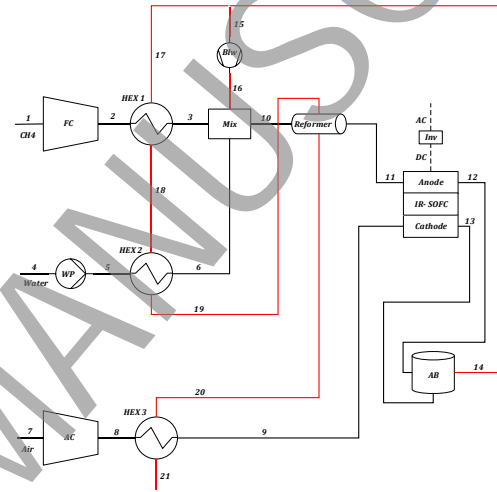
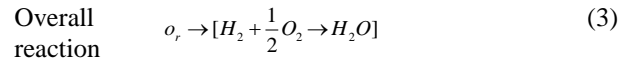
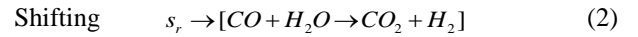
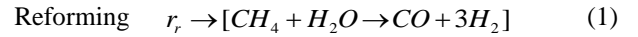

Fig. 1. Schematic of the proposed SOFC system

The dominant chemical reactions occurring in the SOFC are as following:



The fuel utilization factor and relation between the cell parameters and overall reaction are defined as following:

$$U_f = \frac{(\text{Fuel})_{\text{consumed}}}{(\text{Fuel})_{\text{supplied}}} = \frac{o_r}{\dot{n}_{H_2,11} + 3r_r + s_r} \quad (4)$$

$$j = 2Fo_r / N_c A_c \quad (5)$$

Finally, the power generation is calculated as following:

$$\dot{W}_{AC,inv} = \eta_{inv} \times N_c \times V_c \times I \quad (6)$$

$$V_c = V_n - V_{loss} = V_n - (V_{ohm} + V_{act} + V_{con}) \quad (7)$$

Discussion and results

Regarding the Figs. 2, 3 for the lower values of current density and higher values of SOFC temperature; the efficiency of the system is improved. These are because even though at low currents and higher fuel mass flow rates; the power production of the system is decreased; the fuel mass flow rate is also reduced more intensively.

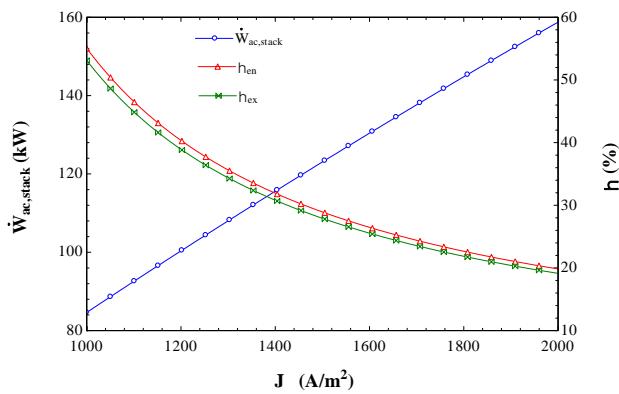

Fig. 2. Effects of current density on the power production and system energy as well as the exergy efficiencies

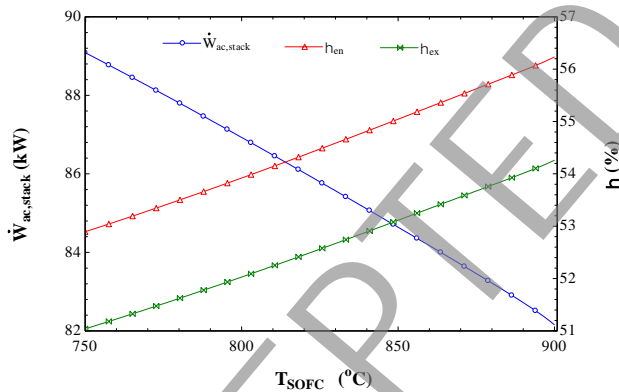

Fig. 3. Effects of SOFC temperature on the power production and system energy as well as the exergy efficiencies

Conclusions

Lower current densities and higher operating temperatures is suggest for SOFC systems with EGR form viewpoints of energy and exergy.

References

[1] M. Halmann and A. Steinfeld, Fuel saving, carbon dioxide emission avoidance, and syngas production by tri-reforming of flue gases from coal- and gas-

fired power stations, and by the carbothermic reduction of iron oxide, *Energy*, 31(15) (2006) 3171–3185.

- [2] M. Sadeghi, A. Chitsaz, S. M. S. Mahmoudi, and M. A. Rosen, Thermoeconomic optimization using an evolutionary algorithm of a trigeneration system driven by a solid oxide fuel cell, *Energy*, 89 (2015) 191–204.
- [3] R. Dietrich, J. Oelze, A. Lindermeir, C. Spitta, M. Steffen, T. Küster, S. Chen, C. Schlitzberger, and R. Leithner, Efficiency gain of solid oxide fuel cell systems by using anode offgas recycle - Results for a small scale propane driven unit, *Journal of Power Sources*, 196 (17) (2011) 7152–7160.
- [4] D. Saebea, Y. Patcharavorachot, and A. Arpornwichanop, Analysis of an ethanol-fuelled solid oxide fuel cell system using partial anode exhaust gas recirculation, *Journal of Power Sources*, 208 (2012) 120–130.
- [5] M. Lo Faro, A. Vita, L. Pino, and A. S. Aricò, Performance evaluation of a solid oxide fuel cell coupled to an external biogas tri-reforming process, *Fuel Processing Technology*, 115 (2013) 238–245.
- [6] M. R. Walluk, J. Lin, M. G. Waller, D. F. Smith, and T. A. Trabold, Diesel auto-thermal reforming for solid oxide fuel cell systems: Anode off-gas recycle simulation, *Applied Energy*, 130 (2014) 94–102.
- [7] A. S. Mehr et al, Solar-assisted integrated biogas solid oxide fuel cell (SOFC) installation in wastewater treatment plant: Energy and economic analysis, *Applied Energy*, 191 (2017) 620–638.
- [8] Manenti, F., Pelosato, R., Vallevi, P., Leon-Garzon, A.R., Dotelli, G., Vita, A., Faro, M.L., Maggio, G., Pino, L. and Aricò, A.S., Biogas-fed solid oxide fuel cell (SOFC) coupled to tri-reforming process: Modelling and simulation, *international journal of hydrogen energy*, 40(42) (2015) 14640-14650.
- [9] M. Rokni, Addressing fuel recycling in solid oxide fuel cell systems fed by alternative fuels, *Energy*, 137 (2017) 1013–1025.
- [10] A. Chitsaz, M. Sadeghi, M. Sadeghi, and E. Ghanbarloo, Exergoenvironmental comparison of internal reforming against external reforming in a cogeneration system based on solid oxide fuel cell using an evolutionary algorithm, *Energy*, 144 (2018) 420–431.