



Design and simulation of a biosensor based on a microelectromechanical resonator array

M. Mehdipoor¹, H. Badri Ghavifekr^{2*}

Electronics Department, Faculty of Electrical Engineering, Sahand University of Technology, Tabriz, Iran

ABSTRACT: The use of microfluidic systems for various applications such as lab-on-chip, drug delivery, and micro chemical reactors is increasing day by day and several sensors have been provided to control and develop these microsystems. In this paper, a biosensor based on microelectromechanical systems was introduced with direct application in liquid environment for digital microfluidic systems that have the ability to be integrated with various fluidics components such as delivery, separation, and mixing. The proposed sensor comprises semi-sized coupled microresonators which vibrate in parallel to the substrate so that it can be integrated between the plane electrodes in digital microfluidics systems. Active area of the sensor is located in the center of the structure and immobilized for capturing any special biological targets. Due to in-plane vibration of the sensor, the viscous damping is low enough to achieve measurable quality factor by resonator. The total system is simulated by finite element methods and the results demonstrate that the appropriate vibration frequency for in-plane motion of the sensor is 16.5 kHz. In addition, the quality factor and mass sensitivity are 49 and 100 Hz/ μg , respectively, which are comparable to sensors with similar fluidics applications.

Review History:

Received: Aug. 17, 2020

Revised: Jan. 16, 2021

Accepted: Jan. 22, 2021

Available Online: Mar. 03, 2021

Keywords:

Microelectromechanical resonator

Digital microfluidics

Biosensor

Damping.

1- Introduction

One of the biggest challenges in the state of the art of the diagnostics systems such as lab-on-chip technologies and microfluidics systems is the integration of various components including micropump, microsenser, micromixer, and reactor. So far, a large number of resonators based on microelectromechanical systems have opened a new horizon for medical and biological applications due to their features such as high-quality factor, real-time, small size and ability to be integrated with electronic devices [1]. Due to the small size of these sensors, an array of coupled microresonators can be fabricated on a single chip without structural complexity [2].

Almost all digital microfluidic sensors require the detection and measurement of bio-particles in a liquid medium, but the sensitivity and mass resolution of microsensors in a liquid medium reduced because of the high surface-to-volume ratio at that scale and high adhesive damping to elastic energy.

In this study, in accordance with Coupled MicroResonator Array (CMRA) systems, a microresonator sensor with integration ability with digital microfluidic components is presented in

Fig. 1. The system consists of a number of semi-sized microsensors coupled by springs. It has three main parts including electrostatic comb-drive actuators, capacitive sensors and the active zone located in the middle of the structure.

*Corresponding author's email: badri@sut.ac.ir

According to Fig. 1, the droplets encapsulating bio-particles are driven towards the active zone and by placing these particles on the surface of the active region, the total mass of the structure increases slightly, so the oscillating frequency of the sensor changes.

By rotary actuation of electrostatic comb drives, the proposed sensor vibrates parallel to the substrate with the lowest damping and the quality factor of output signal is comparable to other sensors with similar application [3, 4] and can be used to control other digital microfluidic components such as delivery, separation, mixing, reactant, and mixer systems.

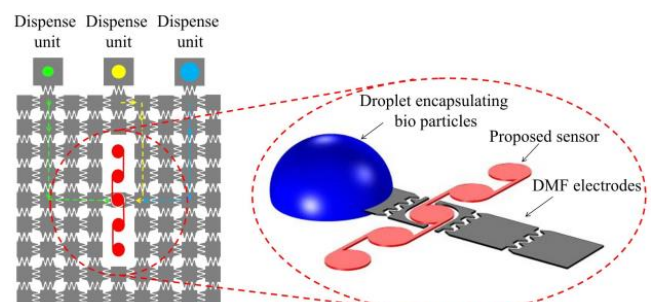

Fig. 1. Overview of integration of proposed sensor in digital microfluidics



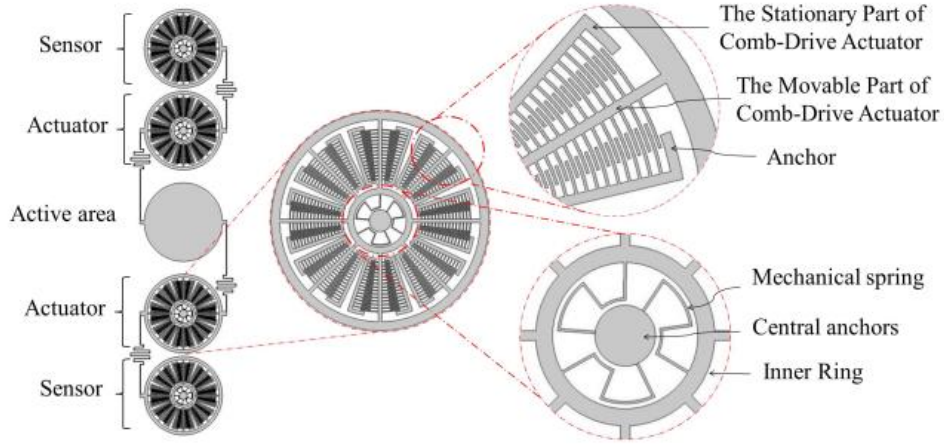

Fig. 2. Different components of the proposed biosensor including active area, actuators, and sensors

2- Performance and Design of the Sensor

This sensor consists of several resonators with 250 μm radius connected in series by springs and the central part of it is the active zone. According to Fig. 2, by applying voltage to actuators, the generated electrostatic force causes torque and in-phase rotation on both sides of the active area.

Given that the sensor is proposed for liquid environment and squeeze damping has impressive effect on the performance of resonating structures, so a frequency is applied to actuators that slide damping occurs which has a slight effect on quality factor.

The proposed fabrication method for the sensor is POLYMUMPS which uses a thin film of gold for immobilizing bio-particles on the active zone [5, 6].

3- Lumped-mass Model, Damping Coefficient

Lumped-mass model was used to analyze the performance of the proposed sensor in reduced form as shown in Fig. 3.

where, I_a , I_s , and I_{az} are inertia of actuators, sensors and active area, respectively, k is stiffness coefficient of the anchored springs, k_c is torsional stiffness of the coupling springs, θ_a , θ_s , and θ_{az} are angular displacement of actuators, sensors and active area, respectively, and c_a and c_s are damping values of sensors and actuators.

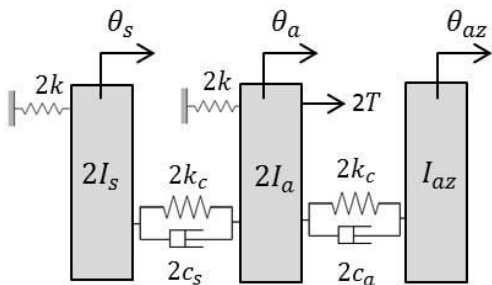

Fig. 3. Reduced Lumped-mass model of the sensor

Angular displacement equations are:

$$\begin{cases} 2I_s \ddot{\theta}_s + 2c_s (\dot{\theta}_s - \dot{\theta}_a) + 2k_c (\theta_s - \theta_a) + 2k\theta_s = 0 \\ 2I_a \ddot{\theta}_a + 2c_s (\dot{\theta}_a - \dot{\theta}_s) + 2c_a (\dot{\theta}_a - \dot{\theta}_{az}) + 2k_c (\theta_a - \theta_s) + 2k_c (\theta_a - \theta_{az}) + 2k\theta_a = 2T(t) \\ I_{az} \ddot{\theta}_{az} + 2c_a (\dot{\theta}_{az} - \dot{\theta}_a) + 2k_c (\theta_{az} - \theta_a) = 0 \end{cases} \quad (1)$$

$T(t)$ is an actuator torque and ω is damping angular frequency. Natural frequencies of the system are obtained under the free vibration conditions.

To achieve viscous damping in lower surface of the sensor and active area, couette-type and stokes-type models [7] are used respectively as Eqs. (2) and (3).

$$c_g = \mu_g A / h \quad (2)$$

$$c_v = \sqrt{\rho \omega_0 \mu_v / 2A} \quad (3)$$

where, μ_g , A , and h are dynamic viscosity of air, overlapped area and air gap, respectively, and ρ , μ_v are density and dynamic viscosity of liquid, respectively.

4- Discussion and Results

In order to investigate natural frequencies and the frequency response of the proposed sensor three-dimensional simulations have been done by finite elements methods. There are few frequencies that the structure vibrates parallel to the substrate as listed in Table 1. As shown in Fig. 4, at $f=16.5$ kHz maximum in-phase actuation occurs in electrostatic rotary comb-drives.



Fig. 4. Demonstration of in-plane vibration of the sensor at $f = 16.5$ kHz

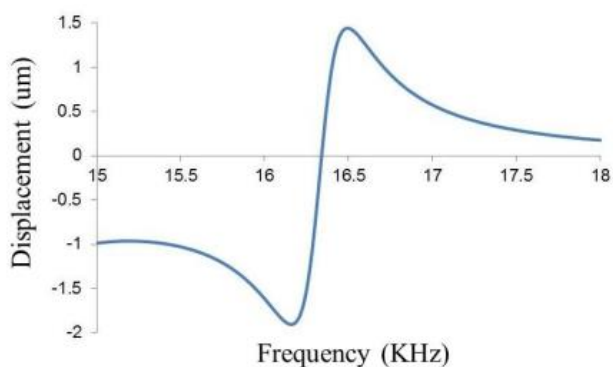

Fig. 5. Frequency response of sensor displacement

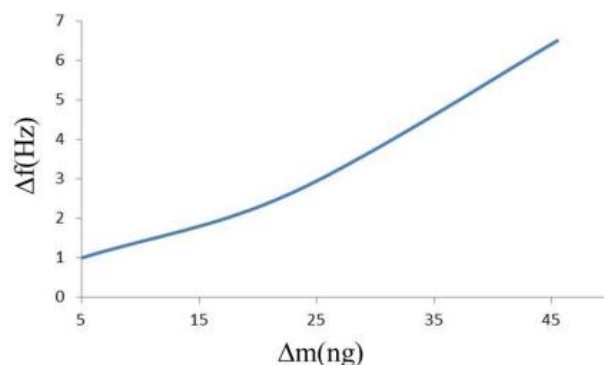

Fig. 6. Diagram of frequency shift vs. added mass

Table 1. Different values of natural frequency with in-plane vibration

n	f (kHz)
1	8.01
2.a	13.96
2.b	13.99
3.a	16.47
3.b	16.50
4.a	45.44
4.b	45.53
5.a	46.175
5.b	46.232
6.a	46.68
6.b	46.787

By applying the mentioned damping and electrostatic forces of $8e-7$ N, the desired frequency response is obtained by measuring the displacement at one point of the sensor as shown in Fig. 5.

In spite of high viscous damping on the active area, Fig. 5 shows that the quality factor is 49, which is significantly comparable to sensors with similar fluid applications [3, 4]. Although it will be less than this value in practice, this sensor has required innovativity for digital microfluidics applications. Besides frequency response, the mass resolution of $100 \text{ Hz}/\mu\text{g}$ was obtained according to Fig. 6.

5- Conclusions

In this paper, a biosensor based on MEMS technology and coupled resonators is presented for digital microfluidic applications, in which electrostatic comb drives system are used for both excitation and sensing. Due to the direct contact of sensor with the fluid in digital microfluidics platforms, it vibrates parallel to the substrate to minimize the viscous damping effect on output signal. Using finite element simulations, the desired working frequency and quality factor are 16.5 kHz and 49 , respectively, which are comparable to other existing sensors with similar fluid applications. In practice, it is possible for fluid to leak to the bottom of the active area and reduce the quality factor; however, the proposed sensor is innovative enough for digital microfluidics applications.

References

- [1] R. Abdolvand, B. Bahreyni, J. Lee, F. Nabki, Micromachined resonators: A review, *Micromachines*, 7(9) (2016) 160.
- [2] M. Spletzer, A. Raman, H. Sumali, J.P. Sullivan, Highly sensitive mass detection and identification using vibration localization in coupled microcantilever arrays, *Applied Physics Letters*, 92(11) (2008) 114102.
- [3] F. Castonguay, Increasing the quality factor of microcantilevers in a fluid environment, McGill University Library, 2010.
- [4] C. Vančura, I. Dufour, S.M. Heinrich, F. Josse, A. Hierlemann, Analysis of resonating microcantilevers operating in a viscous liquid environment, *Sensors and Actuators A: Physical*, 141(1) (2008) 43-51.
- [5] S. Zhang, N. Wang, Y. Niu, C. Sun, Immobilization of glucose oxidase on gold nanoparticles modified Au electrode for the construction of biosensor, *Sensors and Actuators B: Chemical*, 109(2) (2005) 367-374.
- [6] T. Siepenkoetter, U. Salaj-Kosla, E. Magner, The immobilization of fructose dehydrogenase on nanoporous gold electrodes for the detection of fructose, *ChemElectroChem*, 4(4) (2017) 905-912.
- [7] N. Lobontiu, Dynamics of microelectromechanical systems, Springer Science & Business Media, 2014.

HOW TO CITE THIS ARTICLE

M. Mehdipoor, H. Badri Ghavifekr, *Design and simulation of a biosensor based on a microelectromechanical resonator array*, *Amirkabir J. Mech. Eng.*, 53(Special Issue 6) (2021) 911-914.

DOI: 10.22060/mej.2021.18867.6907

