



Numerical Investigation of Upstream Ramp Effects on the Cooling Performance by Cylindrical and Fan-Shaped Hole

S. S. mousavi¹, N. Amanifard¹, H. Mohaddes Deylami^{1*}, M. Naghashnejad²

¹Department of Mechanical Engineering, University of Guilan, Rasht, Iran

²Mechanical Engineering Department, University of Oklahoma, Oklahoma, USA

ABSTRACT: In this study, numerical analysis has been employed to investigate of upstream ramp effects on the flow and thermal field of incompressible, steady, turbulence three dimensional film cooling through a single row of inclined cylindrical and fan-shaped hole. The computational methodology includes the use of a structured, non-uniform hexahedral grid consisting of the main flow channel, the coolant delivery tube and the feeding plenum. The Low Re K- model is adopted as the turbulence model. In the present study, computations are performed for the flowing range of film cooling parameters: streamwise injection angle 35 deg; film-hole length-to-diameter ratio of 1.75; blowing ratio of 0.5, 1, 1.5 and 2 and density ratio of 1.6. The results show that at lowest blowing ratio ($M=0.5$) the presence of the upstream ramp for cylindrical hole is in useful. The fan-shaped hole creates better film cooling performance in all blowing ratio compared with the cylindrical hole. As well as in both cases, the fan-shaped and cylindrical hole, the upstream ramp improves the film cooling effectiveness by incrementing blowing ratio. Last but not least, an optimum film cooling geometry for studied cases is occurred on flat plate model by fan-shaped hole at blowing ratio of 0.5.

Review History:

Received: 6 January 2016

Revised: 16 March 2016

Accepted: 9 May 2016

Available Online: 11 November 2016

Keywords:

Upstream ramp

Film cooling

Fan-shaped hole

Adiabatic effectiveness

Numerical investigation

1- Introduction

Gas turbine engines operate at high temperatures. Thermal efficiency and power output of these modern turbines can be increased through higher combustor exit temperatures. Therefore, the necessity for heightening of engine performance leads to an increase in the turbine inlet temperatures. This high temperature leads to greater thermal stress on the turbine blade. In order to avoid the detrimental effect of contact between hot gases and blade surface, cooling methods are employed. Among different cooling methods which have been designed, film cooling is an advanced technology which can be applied to gas turbines. A considerable number of studies [1–3] have been conducted to understand the mechanisms of film cooling. The main goal is to optimize the design of film cooling systems for effective film cooling with a minimum amount of coolant. Effect of geometry variations of cooling holes on the film cooling effectiveness has been studied by Saumweber and Schulz [4]. It should be noted that coolant jet injection to hot flow, leads to increase hydrodynamic disturbances in the turbulent boundary layer. For this reason, in recent years, using of the upstream ramp has been proposed as an effective method to enhance the efficiency of the film cooling [5]. So far, comprehensive numerical investigation has not been occurred on the effect of upstream ramp by fan-shaped hole on film cooling performance. The aim of the present study is to investigate the effects of upstream ramp on flow and temperature field at four blowing ratios of 0.5, 1, 1.5 and 2, and density ratio of 1.6 through a single row of inclined fan-shaped and cylindrical hole compared with flat plate model.

2- Geometric Model and Computational Grids

Fig. 1 shows the 3-D computational domain that is based on reported experimental study [1], for a row of cylindrical hole in the flat plate.

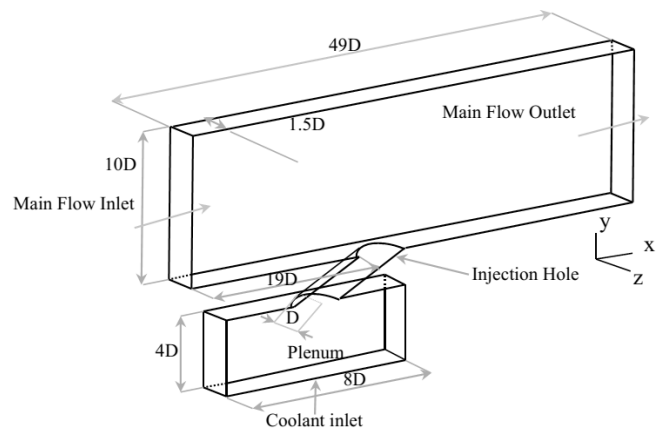

Fig. 1. Computational sketch based on the experimental work of Sinha et al. [1].

Computational domain is subdivided into three main parts: main flow channel, cooling hole and coolant supply channel (plenum). Cylindrical and fan-shaped hole has been employed in the current study. The diameter of the injection hole (D) is 12.7 mm that inclines at 35° along the mainstream flow direction. For cylindrical hole, length to diameter ratio is 1.75 and for fan-shaped hole, the length of cylindrical portion is $L=1D$ and the expansion angle is $\beta=12^\circ$. To evaluate the flow field, the physical domain is subdivided to subdomain with dimensions of $49D \times 10D \times 1.5D$ and $8D \times 4D \times 1.5D$ in x, y

Corresponding author, E-mail: hmohaddesd@gmail.com

and z directions. In order to reduce the computational cost of the numerical procedure, the geometry model is simplified just half of one pitch extent.

The geometry was built up and meshed using GAMBIT software. A structured non-uniform fine grid mesh with hexahedral cell topology is generated. A grid sensitivity study leads to the 809,596 grid points for cylindrical hole over the flat plate model.

3- Governing Equations and Computational Method

System of non-linear partial differential equations governing the flow and thermal fields including continuity, momentum and energy equations have been solved. Flow is 3-D, incompressible and steady. For simulations, Low Re k -turbulence model has been used which predicts the film cooling flow in a better way.

The solution of Reynolds-average form of Navier-Stokes equations includes a cell centered finite volume method is performed using the FLUENT solver. SIMPLE algorithm is applied for coupling of velocity-pressure equations.

4- Results

Four different cooling geometries have been studied: flat plate model by cylindrical hole, upstream ramp with cylindrical hole, flat plate model with fan-shaped hole and upstream ramp with fan-shaped hole. In order to validate the numerical solutions of this work, the computational result of flat plate model with cylindrical hole at $M=0.5$ and $DR=1.6$ has been compared with the experimental data reported by Sinha et al [1] for effectiveness along the centerline. The agreement between computational solution and the experimental data is very good.

At the lowest blowing ratio ($M=0.5$), as shown in Fig. 2, the flat plate model by fan-shaped hole geometry provides the best cooling performance. In this position, using the upstream ramp appears to be detrimental for the cylindrical hole specially.

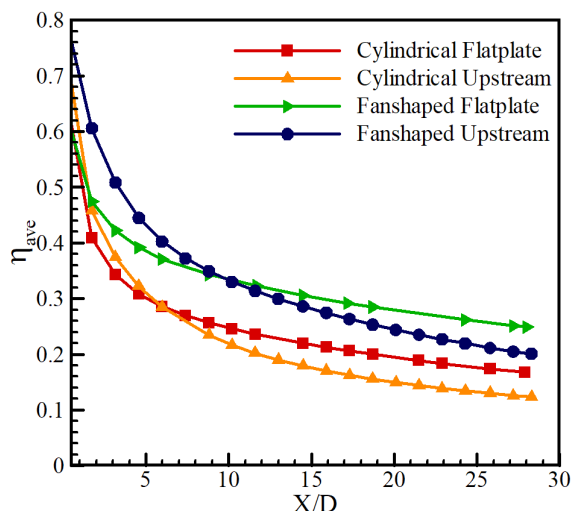

Fig. 2. The laterally averaged film cooling effectiveness for $M=0.5$

By increasing the blowing ratio, the presence of the ramp, provides an improvement on cooling performance through both the fan-shaped and especially cylindrical holes. Because

it weakens the effect of the horseshoe vertices.

For the largest blowing ratio ($M=2$), as illustrated in Fig. 3, laterally averaged effectiveness trend is consistent, but decreases with a great rate immediately downstream of the hole; and increases again. This increase suggests that the jets have reattached to the wall after detached.

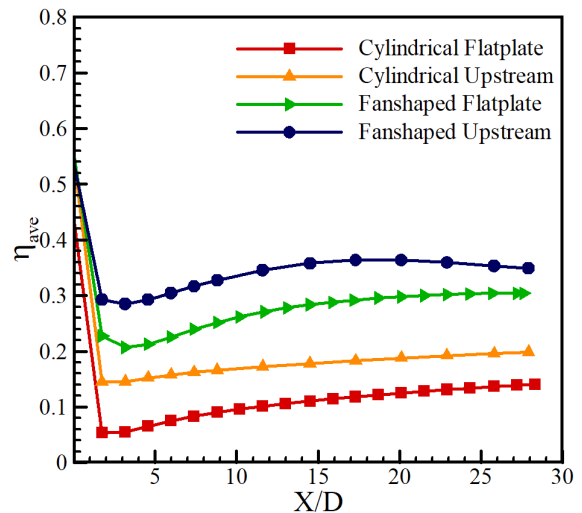

Fig. 3. The laterally averaged film cooling effectiveness for $M=2$

5- Conclusions

The adiabatic film cooling effectiveness of fan-shaped and cylindrical hole have been numerically investigated at different blowing ratios for two models: flat plate and upstream ramp. The main conclusions from this study can be summarized as follows:

- The presence of the upstream ramp for cylindrical and fan-shaped holes is useless at lower blowing ratios ($M=0.5$). Because coolant jet has low momentum and after exiting from the hole, immediately draw behind the ramp. Consequently, the film cooling performance is reduced.
- The film cooling effectiveness of fan-shaped hole is generally better than the configuration with cylindrical hole in the same position. This is due to reduction in the penetration of the coolant into the hot gas and also improvement in the lateral spreading of the coolant.
- By increasing the blowing ratio, the presence of the upstream ramp causes that the boundary layer flow creates from the interaction between coolant jet and hot gas, away from the surface; this phenomena leads to eliminate the horseshoe vortex at the base of the cooling jet, and allows the coolant to spread out more laterally. Consequently, adiabatic film cooling effectiveness was improved.
- From this research, it is found that an optimum film cooling effectiveness for studied cases is occurred on the flat plate model by fan-shaped hole geometry at blowing ratio of 0.5.

References

- [1] A.K. Sinha, D.G. Bogard, M.E. Crawford, Film-cooling effectiveness downstream of a single row of holes with variable density ratio, *ASME Journal of Turbomachinery*, 113 (1991) 442-449.

- [2] J.R. Pietrzyk, D.G. Bogard, M.E. Crawford, Hydrodynamic Measurements of Jets in Crossflow for Gas Turbine Film Cooling Applications, *ASME Journal of Turbomachinery*, 111 (1989) 139-145.
- [3] M. Naghashnejad, N. Amanifard, H. M. Deylami, A Predictive Model Based on a 3-D Computational Approach for Film Cooling Effectiveness over a Flat Plate Using GMDH-type Neural Networks, *Heat and mass transfer, Springer*, 50 (2014) 139-149
- [4] C. Saumweber, A. Schulz, Effect of Geometry Variations on the Cooling Performance of Fan-Shaped Cooling Holes, *ASME J. of turbomachinery*, 134 (2012) 061008-1-16
- [5] S. Na, T.I.-P. Shih, Increasing adiabatic film cooling effectiveness by using an upstream ramp, *ASME Journal of Heat Transfer*, 129 (2007) 464-471

Please cite this article using:

S. S. mousavi, N. Amanifard, H. Mohaddes Deylami, M. Naghashnejad, Numerical Investigation of Upstream Ramp Effects on the Cooling Performance by Cylindrical and Fan-Shaped Hole, *Amirkabir J. Mech. Eng.*, 50(4) (2018) 883-892.

DOI: 10.22060/mej.2016.809



