



Design of Optimal Fuzzy Controllers for Semi Active Vibration Suppression of Multi-Floor Buildings Based on a Distributed Parameter Model and Magneto Rheological Dampers

N. Aliakbari¹, H. Moeenfarid^{1,2*}

¹ School of Mechanical Engineering, Ferdowsi University of Mashhad, Mashhad, Iran

² Center of Excellence in Soft Computing and Intelligent Information Processing, Ferdowsi University of Mashhad, Mashhad, Iran

ABSTRACT: The main objective of this paper is to propose an optimal fuzzy controller for suppressing the resulting vibration of an earthquake in a five floor building facilitated with magneto rheological damper. To this end, by utilizing the Hamilton's principle, equations of motion of the system are derived based on a distributed parameter model. The mode shapes of the system are found by finite element simulations. A magneto rheological damper is used for each floor. To find the rule base of the fuzzy controller, a single degree of freedom vibratory system is considered and the rules derived from open loop simulations are utilized for controlling the vibration of the building. Spencer's model is employed for analyzing the behavior of the magneto rheological damper. By recognizing the magneto rheological damper behavior as well as having the rule based obtained from single degree of freedom simulations, a fuzzy controller is designed to suppress the vibration of the building. Finally, the genetic algorithm is used to improve the performance of the proposed controller. Comparing the results of semi-active vibration control with passive-on and passive-off control strategies reveals that the suggested fuzzy controller can effectively reduce the amplitude of the vibration of the building.

Review History:

Received: 23 May 2017

Revised: 25 July 2017

Accepted: 6 September 2017

Available Online: 2 October 2017

Keywords:

Semi active vibration control
Multi-floor building
Magneto rheological dampers
Distributed parameter model
Fuzzy controller

1- Introduction

In recent years, many researchers have tried to develop control algorithms to minimize the damages of the engineering structures such as buildings to the natural disasters. Depending on the control architecture, vibration suppression is categorized to three groups of passive, active and semi-active strategies.

Semi-active controllers have attracted many attentions thanks to their remarkable capabilities. The generated force in semi-active magnetic dampers varies with applied magnetic field which makes these devices very desirable. Bitaraf and Hurlebaus [1] used a simple adaptive control method for controlling the vibration of tall buildings under the effect of Magneto Rheological (MR) dampers. Cha and Agrawal [2] employed a semi-active control strategy along with MR dampers as their hardware device.

As much as the authors know, all previous researchers have utilized lumped parameter model in the dynamic model of the building structures. To overcome this limitation, in this paper, a distributed parameter model which makes use of some MR dampers are employed along with a novel fuzzy controller to suppress the vibration of a five floor building. The proposed controller is optimized and its effectiveness is proved by closed-loop simulation.

2- Methodology

2- 1- Mathematical modeling

A five floor building is considered as shown in Fig. 1.

Using a single mode approximation, the deflection of each beam in this figure is assumed to be as

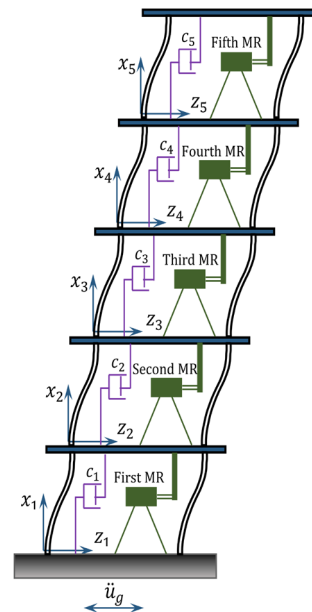

Fig. 1. Schematic view of a five floor building

$$w_i(\hat{x}_i, \hat{t}) = \varphi_i(\hat{x}_i) \hat{q}(\hat{t}), i = 1, 2, \dots, 5 \quad (1)$$

In which φ_i is the deflection shape of the i 'th beam (derived via Finite Element (FE) simulations) and q represents the time part of the response, When the system is vibrating in its first mode.

By employing Eq. (1) into the potential and kinetic energies as well as the damper's virtual work, and finally using Lagrange equations, one gets

Corresponding author, E-mail: h_moeenfarid@um.ac.ir

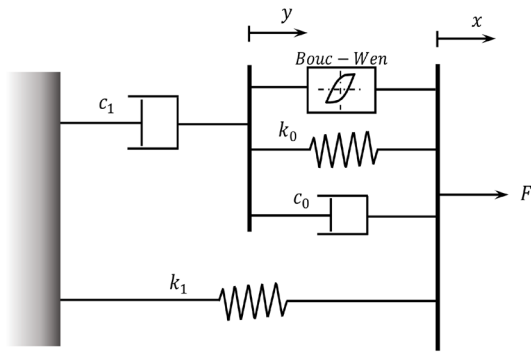

Fig. 2. The MR damper model presented by Spencer [3]

$$q'' + 2\zeta\omega_n q' + q = -\frac{M_2}{M_1}u_g'' + \frac{Q}{M_1\omega_n^2} \quad (2)$$

In this equation, ζ , ω_n , M_1 and M_2 are some constants and Q is a function of the MR damping forces of different floors.

2- 2- Modeling the MR damper

Among many models developed for simulating the behavior of MR dampers, the Spencer's model is preferred due to its excellent capability in predicting the damping forces [3] of the damper shown in Fig. 2.

2- 3- Fuzzy Controller Design

2- 3- 1- Modeling single degree of freedom system

To derive the rule base of the fuzzy controller, one needs to characterize the behavior of the MR damper with respect to the applied voltage. To do so, the single Degree of Freedom (DoF) system shown in Fig. 3 is considered.

With applying different voltages to the MR damper and carrying out time domain simulations, one can drag out sufficient knowledge for extracting "if-then" rules governing the behavior of the system.

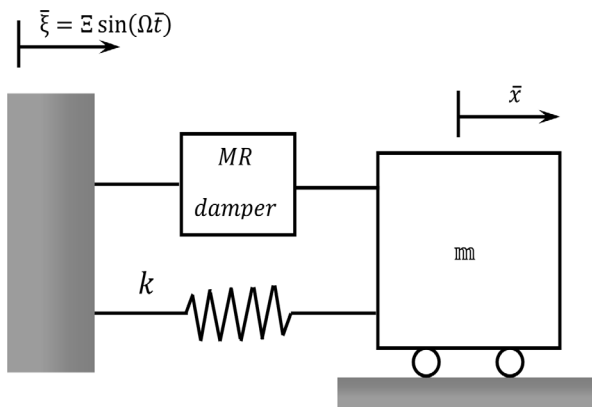

Fig. 3. A spring mass system with an MR damper

2- 3- 2- Fuzzy "if-then" rules

The results of constant voltage simulation of the system, verifies the physical understanding that increasing the voltage leads to larger MR damping force. Based on this understanding, some fuzzy rules can be inferred with the absolute displacement, absolute velocity and relative velocity (between the mass and the support) as its input and the

required voltage as its output. The time response of the single DoF system shown in Fig. 3 under the effect of a support motion and facilitated with such a controller is shown in Fig. 4. It is observed that the proposed controller has effectively suppressed the unwanted vibration of the system. Also the performance of the fuzzy controller is appreciably better than that of a passive-on and passive-off control scheme.

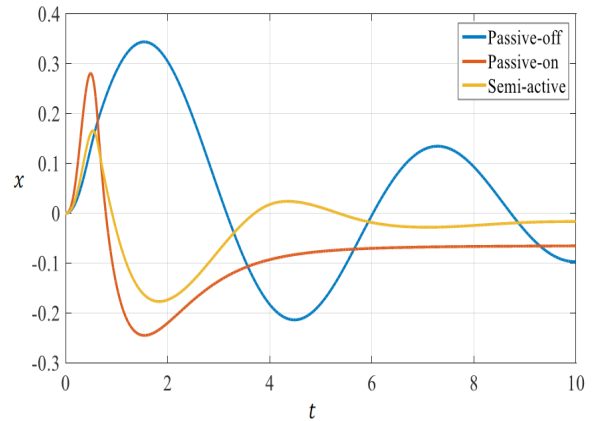

Fig. 4. Time response of the closed-loop single DoF system

2- 3- 3- Fuzzy controller design for suppressing the vibration of a building

The already designed controller is employed to find the required voltage for each of the five MR dampers in the simulated five floor building. Genetic algorithm is used to tune the bounds of the membership functions of the input and output variables of the controller. The fitness function is considered to be

$$p(w_{i,abs}, w'_{i,abs}, w'_{i,rel}) = s_1 \max |q| + s_2 RMS(q) \quad (3)$$

The first and the second terms in the right hand side of this equation represent the maximum displacement and the root mean square of the building response and s_1 and s_2 are two constants which are selected by trial and error.

Considering the acceleration of the ground as a white noise, the dynamic of the system with implemented controllers is simulated in time domain. The results which are shown in Fig. 5 demonstrate the superiority of the fuzzy controller over the passive-on and passive-off control schemes.

3- Conclusion

Vibration suppression in engineering structures such as buildings has been of primary importance in recent years. MR dampers are one of the most important semi active devices that can be employed for achieving this purpose. On the other hand, researchers usually use lumped parameter models for simulating buildings under the effect of earthquake which is not sufficiently accurate. So the objective of the current paper was to propose a distributed parameter model along with a novel optimal fuzzy controller to reduce the vibrations of a five floor building resulted from an earthquake. Simulation result reveals that the designed controller has successful performance. The approach presented in this paper can be further utilized for performance improvement of MR based semi active devices to reduce the vibration level in other engineering structures.

References

- [1] M. Bitaraf and S. Hurlebaus, Semi-active adaptive control of seismically excited 20-story nonlinear building, *Engineering Structures*, 56 (2013) 2107-2118.
- [2] Y. J. Cha and A. K. Agrawal, Seismic retrofit of MRF buildings using decentralized semi-active control for multi-target performances, *Earthquake Engineering & Structural Dynamics*, 46 (2017) 409-424, .
- [3] B. Spencer, S. Dyke, M. Sain, and J. Carlson, "Phenomenological model for magnetorheological dampers," *Journal of engineering mechanics*, 123 (1997) 230-238, .

Please cite this article using:

N. Aliakbari, H. Moeenfard, Design of Optimal Fuzzy Controllers for Semi Active Vibration Suppression of Multi-Floor Buildings Based on a Distributed Parameter Model and Magneto Rheological Dampers, *Amirkabir J. Mech. Eng.*, 50(5) (2018) 43-46.

DOI: 10.22060/mej.2017.12919.5470



