

# Investigation of Thermo-Hydraulic Parameters of Reactor Containment due to Cold-Leg Break Accident

M.M.Sadeghiazad<sup>1,2\*</sup>, F.Choobdar Rahim<sup>3</sup>

<sup>1</sup>Associate Professor, Department of Mechanical Engineering, Azarbaijan Shahid Madani University, Tabriz, Iran.

<sup>2</sup>Department of Mechanical Engineering, Urmia University of Technology, Urmia, Iran.

<sup>3</sup>Ph.D. Candidate, Department of Mechanical Engineering, Urmia University of Technology, Urmia, Iran.

## ABSTRACT

Since the nuclear energy has been recognized as a useful energy, the subject of structure, operation and safety and environmental protection have also been important. In the nuclear reactors, one of the most dangerous accidents that can occur is the loss of coolant accident, that the most important of these events is the guillotine breaking in cold or hot leg coolant, which, this will melt the reactor core if it is not stopped. This paper presents one of the most dangerous accidents in reactor containments known as Loss of Coolant Accident in its worst condition which is called Large Break Loss of Coolant Accident. The specific type of large Break Loss of Coolant Accident is Double Ended Cold Leg break which means totally guillotine type of break in cold leg pipe. This modeling is performed in single volume method in Advanced Pressurized water reactor which is one of the most sophisticated safe reactors that has ever been built. The conservation mass and energy equations have been used in this modeling and the modeling software applied in our analysis is MATLAB, and the results are compared with the Advanced Pressurized-1000 water reactor safety, security and environmental reports.

## KEYWORDS

Reactor Containment, Thermohydraulic, Single Volume Modeling, Guillotine Fracture, Two Phase.

---

\* Corrospoding Author: Email: [m.sadeghiazad@azaruniv.ac.ir](mailto:m.sadeghiazad@azaruniv.ac.ir)

## 1. Introduction

During a severe accident, a large amount of radioactive fission products is generated and the goal of the containment system is to avoid or limit the release of these fission products to the external environment. This goal is achieved through restriction of accidents or by using containment safety systems limiting the dangerous effects of the event. Therefore, the containment plays a basic role in safety. AP1000 is a two loop 1000 MWe pressurized water reactor (PWR) with passive safety features and extensive plant simplifications that enhances the construction, operation, maintenance, and safety [1]. The AP1000 safety-related systems include the following (Fig. 1):

1. Passive core cooling system (PXS)
2. Passive containment cooling system (PCS)
3. Main control room emergency habitability system (VES)
4. Containment isolation

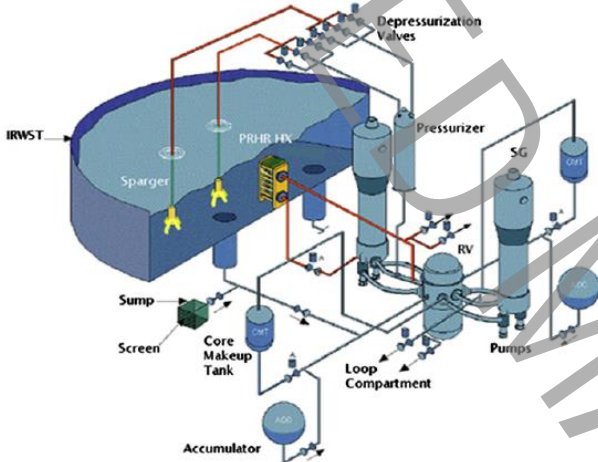
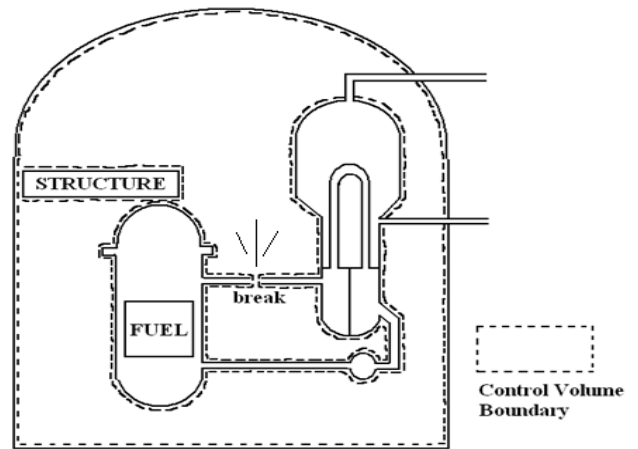

**Fig.1. AP1000 RCS and Passive Core Cooling System [1].**

The Loss of coolant accident (LOCA) is most likely to occur in 'water cooled reactors', where the stored energy content of the high pressure, high temperature coolant may be released to the containment by rupture of an exposed pipe. Due to the importance of safety in nuclear power plants, accident analysis should be performed in power plant design, one of the most important events to consider is the loss of coolant accidents. There has been a lot of research and studies in this field such as: Numerical simulation study of LBLOCA accident for AP1000 reactor by SCDAP / RELAP 4.0 computational code [2], Simulation of SBLOCA AP1000 Reactor accident using RELAP5-MV code and comparing results with NOTRUMP code [3], Thermal-hydraulic and stress analysis of AP1000 reactor containment during LOCA in dry cooling mode [4].

## 2. Methodology

Containment modeling is performed in several ways. In single volume analysis, it is assumed that the containment has a single volume with single pressure and temperature. Clear examples of time varying flow processes relevant to nuclear technology are such as: (1) pressurization of the containment due to postulated rupture of the primary or secondary coolant systems; (2) response of a PWR pressurizer to turbine load changes; and (3) BWR suppression pool heat up by addition of primary coolant. Unlike the steady-flow analysis, the variable flow analysis can be performed with equal ease by either the mass control or the volume control approach [5]. Figure 2 is shown control volume for single volume modeling.



**Fig. 2. Control Volume**

For the light water reactor, one postulated accident is the release of primary or secondary coolant within the containment. The magnitude of the peak pressure and the time to reach to peak pressure are of interest for structural considerations of the containment. The fluid released in the containment can be due to the rupture of either the primary or secondary coolant loops. In both cases the assumed pipe rupture begins the blow down. The final state of the water/air mixture depends on several other factors: (1) the initial thermodynamic state and mass of water in the reactor and the air in the containment; (2) the rate of release of fluid into the containment and the possible heat sources or sinks involved; (3) the likelihood of exothermic chemical reactions; and (4) the core decay heat [6]. In the analysis of transient conditions, using the application of the first law of thermodynamics in three subsections including containment air, water vapor initially in the air of containment, and discharged water into the containment from primary system. Heat transfer modeling is performed for AP1000 reactor containment according figure 3.

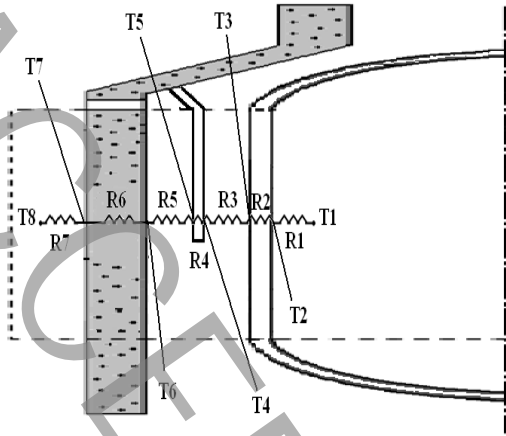

Fig. 3. Multilayer heat resistors

### 3. Discussion and Results

Distribution of pressure and temperature of inside reactor containment with time have been shown in figures 4 and 5 respectively. As it can be seen from these diagrams, the pressure and temperature of the containment increase as the water and steam discharge into the containment, But because after the start of the accident, the reactor safety systems, including the water spray system inside the safety containment, heat removal system through the walls and the accumulators system by draining the water on the outer wall of the containment, reducing the pressure and temperature inside the safety containment.

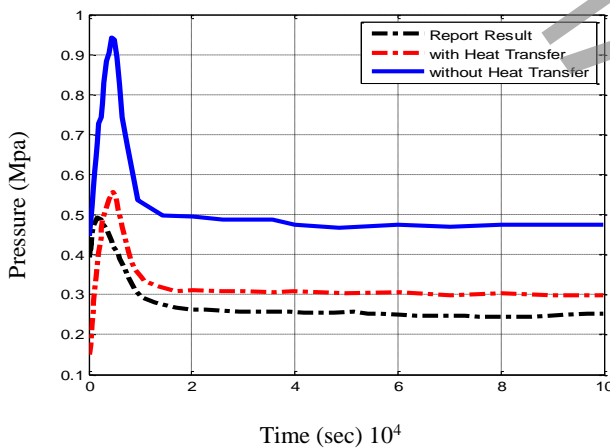

Fig.4. Time variations of safety containment Pressure

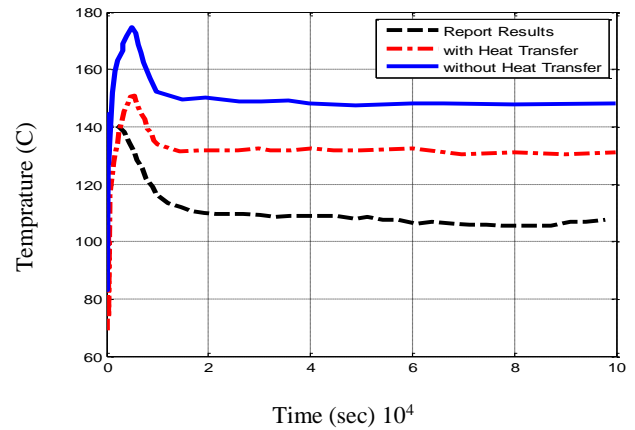

Fig.5. Time variations of safety containment Temperature

### 4. Conclusions

By comparing the results from the model and report [6] it is seen that the two phase simulation of LOCA accident in AP1000 with single volume method is acceptable, also due to little differences observed between the consequences of modeling and report [6], it can be inferred that mathematical procedures and conjectures in transients, equilibrium conditions and heat transfer, with receivable assumptions are useful approximations for AP1000 systems.

### 5. References

- [1] UK Compliance document for AP1000 design, Section A UK safety case Overview, A.2 AP1000 safety philosophy, A 50, (2007).
- [2] Heng Xie, Numerical simulation of AP1000 LBLOCA with SCDAP/RELAP 4.0 cod, Journal of Nuclear Science and Technology, 54(2017) 969-976.
- [3] Eltayeb Yousif, Zhijian Zhang, Zhaofei Tian, and Hao-ran Ju, Simulation and Analysis of Small Break LOCA for AP1000 Using RELAP5-MV and Its Comparison with NOTRUMP Code, Science and Technology of Nuclear Installations, 45(2017) 13.
- [4] Sh. Sheykhi, S. Talebi, M. Soroush, E. Masoumi, Thermal-hydraulic and stress analysis of AP1000 reactor containment during LOCA in dry cooling mode, Nuclear Science and Techniques, 73(2017) 13.
- [5] Neil E. Todreas, Mujid S. Kazimi, NUCLEAR SYSTEMS 1 Thermal Hydraulic Fundamentals, Massachusetts Institute of Technology, HEMISPHERE PUBLISHING CORPORATION 1990, Chapter 7, (2007) 239.
- [6] UK AP1000 Safety, Security and Environmental Report, Chapter 6, Section LOCA, DECL, (2007).