



The Experimental Analyses of Grooved Surface and Magnetic Field Effects on γ -Fe₂O₃/water Nanofluid Pool Boiling

S. Nasiri¹, Sh. Talebi^{1*}, M. R. Salimpour²

¹ Department of Mechanical Engineering, Yazd University, Yazd, Iran.

² Department of Mechanical Engineering, Isfahan University of Technology, Isfahan, Iran.

ABSTRACT: Use of nanoparticle, heater surface expansion and magnetic field applying are important and effective elements on boiling heat transfer. In this article, pool boiling of deionized water and γ -Fe₂O₃/water nanofluid have been analyzed on smooth and copper grooved surface at one atmosphere pressure in the presence and absence of magnetic field, experimentally. The result showed that the boiling heat transfer coefficient of deionized water has increased in circular and rectangular grooved surfaces and has decreased in triangular grooved surface toward the smooth surface. The boiling heat transfer coefficient of nanofluid has increased 24% in circular grooved surface and has decreased 8% and 37% in rectangular and 37% in triangular grooved surfaces. The corners existence and wettability reduction in vertical wall of rectangular and triangular grooves and the bubbles slipping cause thermal resistance increasing toward circle groove. Two flat constant magnets have been used in two sides of boiling reservoir for magnetic field creation. By applying magnetic field with negative gradient, the boiling heat transfer coefficient of nanofluid has enhanced in circular and rectangular grooved surfaces and has reduced in triangular grooved surface. The upward magnetic force causes the formed bubbles diameter decreasing, but groove type is effective on result, too.

Review History:

Received: 30 Jun. 2018

Revised: 23 Sep. 2018

Accepted: 10 Nov. 2018

Available Online: 22 Nov. 2018

Keywords:

Pool boiling

Magnetic nanofluid

Grooved surface

Heat transfer coefficient

Magnetic field

1- Introduction

Many studies done in the field of boiling heat transfer, because of its many applications in industrial processes. There are various ways for boiling heat transfer improvement, such as adding nanoparticles to base fluid, expansion of heater surfaces, heating surface or fluid vibration and electrical or magnetic field applying.

In present article, the effect of grooved surface and magnetic field on deionized water and γ -Fe₂O₃/water ferrofluid pool boiling was investigated experimentally.

2- Experimental Setup

In this article, γ -Fe₂O₃/water ferrofluid was built in one stage method. Dynamic Light Scattering (DLS) test, that indicates magnetic nanoparticles distribution, was done for synthesized nanofluid and according to test result, average of nanoparticle diameter is about 20 nanometer. Also Zeta potential test was done for nanofluid stability investigation and its value for nanofluid was 40 mV that indicates nanofluid has high stability.

The test setup scheme is seen in Fig. 1. The main components of test setup are: copper heater and insulator set, boiling tank, condenser and cooling system, circuit and voltage control system, thermocouples and indicators and two flat magnets.

The smooth heater surface diameter was 40 mm and the average roughness of surface is 213 nm in all tests. The grooved surfaces built by wire cut system. The actual photo of experimental setup is shown in Fig. 2. The groove geometry

has been considered in three types circular, rectangular and triangular, as shown in Fig. 3.

The values of heat flux calculated from Eq. (1):

$$q'' = k \frac{T_2 - T_1}{\Delta x_2} \quad (1)$$

In Eq. (1), k is heater thermal conductivity, T_1 and T_2 are thermocouple's temperatures, that are in 8 and 18 mm distance of heater surface. In Eq. (1) we suppose that heat transfer in heater is one dimensional. The boiling surface temperature is calculated from T_1 and T_2 extrapolation:

$$T_w = T_1 - \frac{\Delta x_1}{\Delta x_2} (T_2 - T_1) \quad (2)$$

The boiling heat transfer coefficient is obtained Newton's cooling law (Eq. (3)):

$$h = \frac{q''}{T_w - T_{sat}} \quad (3)$$

*Corresponding author's email: nozar@ssau.ac.ir



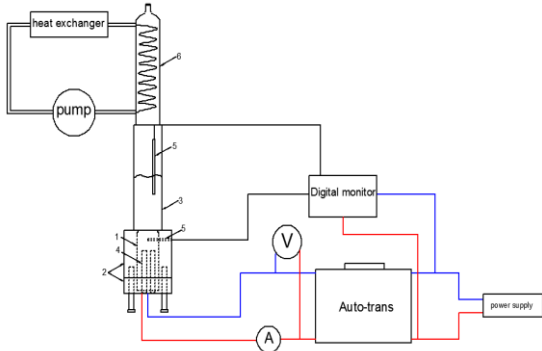

Fig. 1. Hybrid turbine model



Fig. 2. The flow field and boundary conditions

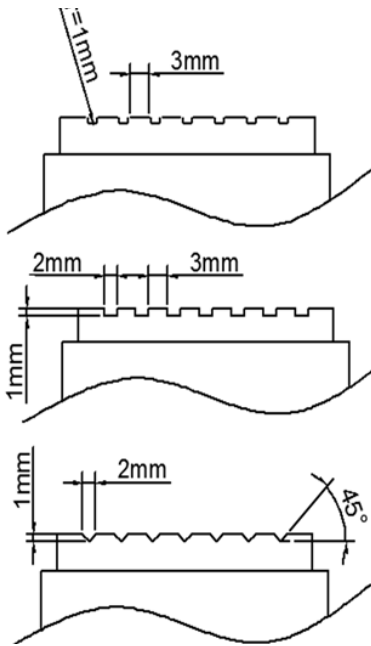

Fig. 3. Verification of straight-bladed turbine total moment coefficient

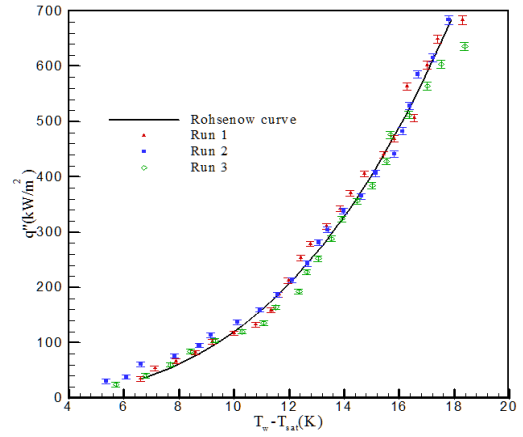

Fig. 4. Comparison of total moment vs. azimuth angle for starting mode

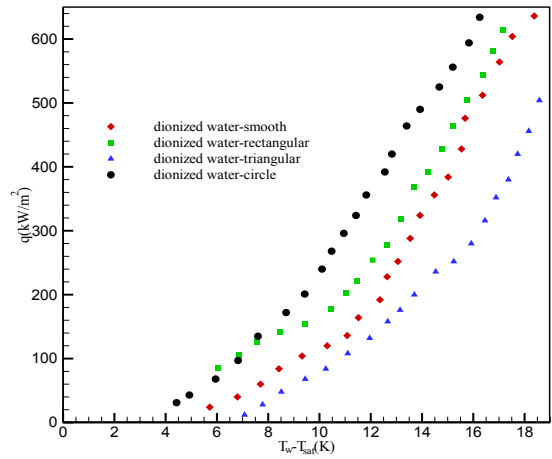

Fig. 5. Comparison of total moment vs. azimuth angle for 30 RPM

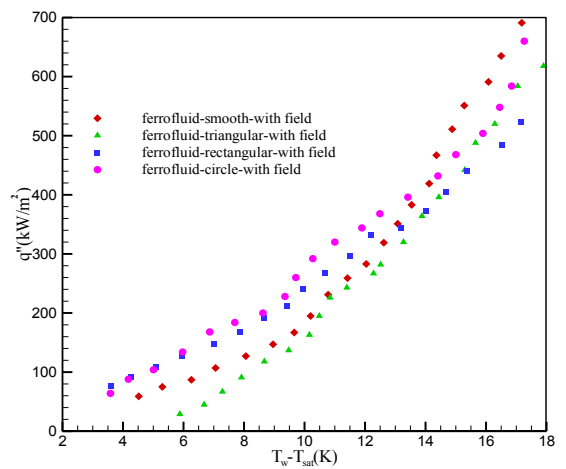

Fig. 6. Comparison of total moment vs. azimuth angle for 60 RPM

3- Results and Discussion

Every test has been done three times and at three days with equal situations for precision and repeatability insurance. For results accuracy confirmation, deionized water boiling on smooth surface has been done and its data has been compared with Rohsenow correlation [1], as shown in Fig. 4.

Boiling test has been done for γ -Fe₂O₃/water ferrofluid with 0.1% volume fraction. The nanofluid boiling heat transfer coefficient has been increased about 20%. The heat transfer improvement cause is related to high thermal conductivity of nanoparticle. Also, ϕ parameter (the ratio of heater surface roughness to nanoparticles diameter) is more than one, the surface nucleation sites increase and heat transfer improves.

For investigation of groove's geometry effect, the results of deionized water boiling test on surface with different grooves have been compared (Fig. 5). The boiling heat transfer coefficient of water on circular and rectangular grooved surfaces increased and on triangular grooved surface has decreased than smooth surface. Although the area of three grooved surface is greater than smooth surface, but groove geometry is effective on created bubbles movement. It was seen in ferrofluid boiling test on grooved surface that ferrofluid boiling heat transfer on circular grooved surface increased and on rectangular and triangular grooved surface decreased than smooth surface. The causes of these changes are nanoparticles deposition in triangular grooves corners and contact angle increasment in vertical wall of groove toward

horizontal wall.

Magnetic field applying with negative gradient at ferrofluid boiling on smooth surface cause's bubbles diameter decrease and bubbles movement from stronger field to weaker field and heat transfer improves. By combination of magnetic field and grooved surface at ferrofluid boiling, according to Fig. 6, the average boiling heat transfer coefficient on circular and rectangular grooved surface has increased 21% and 13% respectively and has decreased on triangular grooved surface 15% toward smooth surface. In fact groove geometry effect has overcome on field effect.

4- Conclusions

In this article, pool boiling of deionized water and γ -Fe₂O₃/water ferrofluid with 0.1% volume fraction has been investigated on smooth and grooved surfaces experimentally and magnetic field effect on boiling studied also. Important parameters, such as nanoparticle diameter, surface roughness, bubbles contact angle, bubble diameter, grooves geometry and magnetic field gradient, have been effective on results

References

- [1] D. Wen, Y. Ding, Experimental investigation into the pool boiling heat transfer of aqueous based γ -alumina nanofluids, Journal of Nanoparticle Research, 7(2-3) (2005) 265-274.

