



## The Importance of the Compatible Combustion and Sub-grid Scale Models on the Simulation of Large-Scale Pool Fire

G. Heidarinejad\* , H. Pasharshahri, M. Safarzadeh

Faculty of Mechanical Engineering, Tarbiat Modares University, Tehran, Iran.

### Review History:

Received: 15 Nov. 2018

Revised: 10 Jan. 2019

Accepted: 11 Mar. 2019

Available Online: 20 Mar. 2019

### Keywords:

Pool fire

Eddy dissipation

Infinite fast chemistry combustion model

Smagorinsky

One-equation sub-grid.

**ABSTRACT:** In this paper, large-scale pool fire behavior has been investigated with large eddy simulation. In order to investigate the efficiency of various combustion models in the pool fire simulation, two combustion models of the eddy dissipation model and infinite fast chemistry in two sub-grid scale models of Smagorinsky and one equation was evaluated. The infinite fast chemistry model has an over-prediction in the reaction rate and flame temperatures in the simulation of pool fire. In addition, the eddy dissipation model, due to the use of time characteristic of turbulence and diffusion, has more accurate results in the prediction temperature field and flow behaviors. The eddy dissipation model with one-equation sub-grid scale model has better prediction for the velocity field and there is a difference of about 5–10 % with the experimental measurements. However, the infinite fast chemistry combustion model can better fit with the Smagorinsky sub-grid scale than one equation sub-grid scale model in the simulation of pool fire. The numerical results predicted by the different combustion models and sub-grid models for vertical velocity along the central line are in the range of experimental results, and almost all models predict the vertical velocity in this line, good.

### 1. Introduction

In general, fire can be divided into two categories of jet fire and plume fire. The criterion for this division is based on the ratio of buoyancy forces to momentum (Richardson number).

Pool fire is a reactive plume and low-kinetic combustion in which buoyancy force is the dominant force on its movement. In the category of pool fire, pool fire with diameter of the fuel source of about 1 meter and above is a large-scale pool fire, and pool fire with a diameter of the fuel source of less than 30 to 50 cm is called a small-scale pool fire [1, 2].

McGrattan [3] conducted the first study on the use of a Large Eddy Simulation (LES) method in open and closed fire simulation. Yang et al. [4] using the LES model with *Fire Dynamics Simulator (FDS)* software, three combustion models of eddy dissipation, infinite fast chemistry and combustion model based on mixture fraction for the fire scenario in a single space room with an entrance. Maragcos et al. [5] modified the coefficients of the eddy dissipation model by comparing two eddy dissipation combustion models and eddy dissipation concept. In this study, the coefficient of the eddy dissipation combustion model was changed from 1 to 8 and it was concluded that coefficient 1 predicts a precise result.

In the present study, the modeling of the open-air pool fire by using simple combustion models, which is in accordance

\*Corresponding author's email: gheidari@modares.ac.ir

with the fire physics, which is usually a fast chemistry kinetic, is considered and the effects of wall was ignored, in other words, in the simple manner of the effect of the combustion model on fire modeling were investigated.

### 2. Governing Equations

Using the Favre filtering method can filter the equations of reactive flow such as continuity, momentum, energy, and species transport equations. Smagorinsky [6] and single equation [7] Sub-Grid Scale (SGS) model for sub-grid stress and infinite fast chemistry and eddy dissipation combustion model was used for single-step reactions, and the radiation model of the discrete-ordinate approach was used for radiation modeling [8].

### 3. Numerical Method

In the present modeling, the fireFoam solver has been used; in the fireFoam solver, the equations are implicitly applied in the program. The value of the local Courant number is considered to be 0.4. For all convective terms in flow equations, turbulent kinetics energy, energy transfer, the transfer of species, the second-order scheme has been used. In this paper, a simulation based on the test carried out by Tieszen et al. [9], was conducted for a methane fuel with a fuel inlet diameter of one meter. for a methane fuel with a fuel inlet diameter of one meter. The amount of intake of fuel was  $0.0666 \text{ kgm}^{-2}\text{s}^{-1}$ . In order to model the pool fire,



the computational domain of  $3 \times 3 \times 3$  m<sup>3</sup> as shown in Fig. 1 was considered, and four types of 216000, 500000, 1000000, 2000000 grids were considered as the study of the effect of the computational grid, and the grid of one million was selected as the main grid.

The results are presented in four cases of Smagorinsky SGS-eddy dissipation combustion model (S\_E), Smagorinsky SGS-infinite fast combustion model (S\_I), one equation SGS-eddy dissipation combustion model (O\_E) and one equation SGS-infinite fast combustion model (O\_I) In order to investigate the compatibility of the combustion model with SGS model in modeling the pool fire.

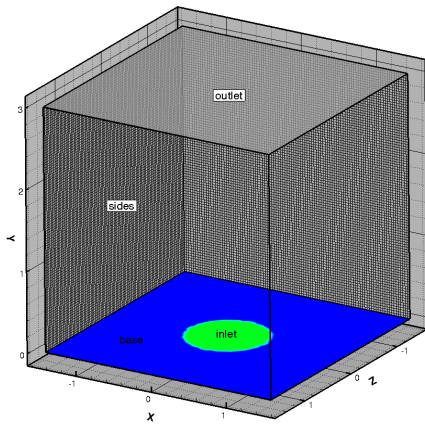
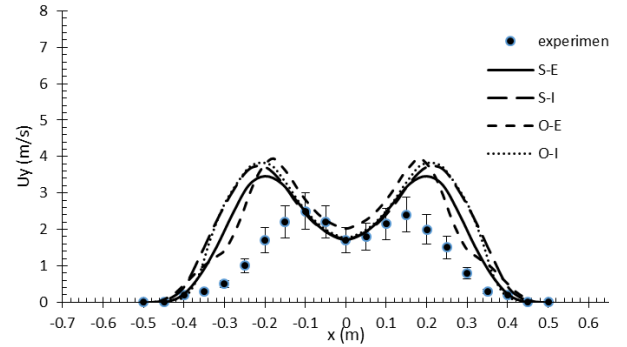

Fig. 1. The computational domain

#### 4. Results

In the pool fire, with a spark or other agent, the fuel around the fuel source starts to ignite. Since the ratio of fuel to air is high around the fuel source, so there is a rich combustion area in this area. By combustion formation, the temperature of the combustion gases as well as the gases surrounding the combustion products increases and, consequently, the density of the mixture decreases. By reducing the density of the mixture relative to the environment, the buoyancy force is activated corresponding to the difference in density of the mixture with the surrounding environment. In the next step, hot gases from the combustion process move upward due to buoyancy forces. In fact, at this stage, the flame is formed and transmitted as a plume to the top and disappears at the end of the flame by interrupting the combustion.

As seen in Fig. 2, between 4 cases, O\_I case predicts the best results, for example, at 0.6 m, the relative error is about 29 %, and at 0.9 m, is about 14 %, which is the error within the range of experimental data error (20%) and, of course, at the  $Y = 0.3$  level, most models have modeled the results with more error, which is due to the fact that in reality near the fuel bed, the combustion starts gradually and therefore, the temperature and consequently the velocity gradually increases, but in the modeling by combustion models based on the fast chemistry combustion with a faster speed than the experimental, and so the difference between numerical and experimental results is more pronounced at this point.



(a)

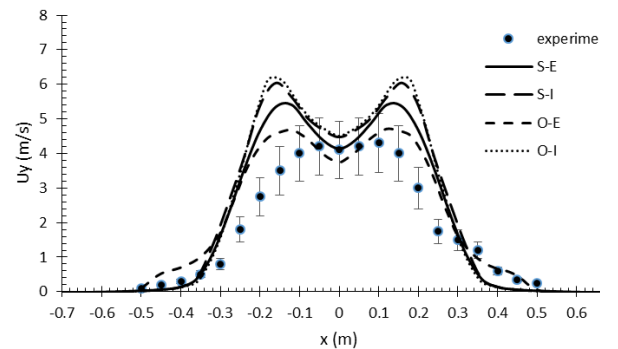

(b)

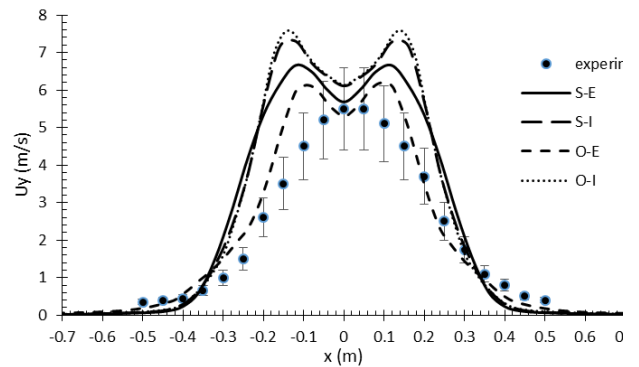

(c)

Fig. 2. Mean vertical velocity at a)  $y = 0.3$  b)  $y = 0.6$  c)  $y = 0.9$  m

#### 5. Conclusions

The prediction of the numerical temperature results in the nature of two combustion models, such as the infinite fast chemistry combustion model. When the fuel and oxidant are encountered, the reaction proceeds according to the equations of the irreversible stoichiometric equation, and therefore the temperature is higher than the eddy dissipation model and when the temperature is more predicted, the energy of the mixture is higher and also the density is lower. Therefore, the buoyancy force on the fluid is higher and therefore the vertical velocity is higher, and vice versa, when the temperature is

lower (in eddy dissipation model), the velocity decreases.

### References

- [1] B.J. McCaffrey, Entrainment and heat flux of buoyant diffusion flames, *NBSIR*, (1982) 82-2473.
- [2] B. McCaffrey, Purely buoyant diffusion flames: Some experimental results. Final Report, Chemical and Physical Processes in Combustion. The National Institute of Standards and Technology (NIST), Miami Beach, (1979) 49.
- [3] K. McGrattan, R. Rehm, H. Baum, Fire-driven flows in enclosures, *Journal of Computational Physics*, 110(2) (1994) 285-291.
- [4] D. Yang, L. Hu, Y. Jiang, R. Huo, S. Zhu, X. Zhao, Comparison of FDS predictions by different combustion models with measured data for enclosure fires, *Fire Safety Journal*, 45(5) (2010) 298-313.
- [5] G. Maragkos, T. Beji, B. Merci, Advances in modelling in CFD simulations of turbulent gaseous pool fires, *Combustion and Flame*, 181 (2017) 22-38.
- [6] R.O. Fox, A. Varma, *Computational models for turbulent reacting flows*, Cambridge Univ. Press, 2003.
- [7] G.-H. Yeoh, K.K. Yuen, *Computational fluid dynamics in fire engineering: theory, modelling and practice*, Butterworth-Heinemann, 2009.
- [8] P.P.S. da Costa, Validation of a mathematical model for the simulation of loss of coolant accidents in nuclear power plants, (2016).
- [9] S. Tieszen, T. O'hern, R. Schefer, E. Weckman, T. Blanchat, Experimental study of the flow field in and around a one meter diameter methane fire, *Combustion and Flame*, 129(4) (2002) 378-391.

