

# Investigation of the surface flame burner functional diagram using chemiluminescence and image analysis

Ziaulhaq Ahmadi, Mohammad Zabetian Targhi\*

Department of Mechanical Engineering, Tarbiat Modares University, Tehran, Iran

Z\_ahmadi@modares.ac.ir

Zabetian@modares.ac.ir

## ABSTRACT

In this study, a fully premixed cylindrical surface flame burner is investigated in laboratory research. The burner was analyzed in heating capacities 11.74-17.14 kW and its equivalence ratio 0.4-1.6. The results are including two sections of spectroscopy and flame image analysis. In the chemiluminescence section, the maximum heat release from the perforated cylindrical burner is obtained by examining the intensity of hydroxyl radiation in the equivalence ratio of 0.8. In the second part of chemiluminescence, the equivalence ratio is estimated by using the  $\text{OH}^*/\text{CH}^*$  intensity ratio and  $\text{OH}^*/\text{power}$  curve fitting from natural flame radiation. The color and state of the flame changed from the equivalence ratio of 1.6 to 0.44, respectively, from green to yellow and red flame, blue and lift-off flame, and eventually blow-off. The satisfactory operation that is stable blue flame without lift-off and flashback is observed in the range of 0.7-0.85. This process was performed for six thermal capacities, and its results were collected in a chart called the functional burner diagram. A satisfactory operation can be selected by a functional diagram in different burner powers.

## KEYWORDS

Cylindrical Burner, Equivalence Ratio, Functional Diagram, Chemiluminescence, Image Analysis

---

\* Corresponding Author: Email zabetian@modares.ac.ir

## Introduction

The quantities that are targeted in combustion by diagnostic methods are the concentration of species, velocity, and the temperature, which is important for the measurement method due to its combustion evaluation. In combustion, diagnostic methods are divided into two main methods. Experimental methods are utilized to monitor combustion regimes by intrusive and non-intrusive techniques[1]. The chemiluminescence technique and image analysis are non-intrusive approaches to investigate stability and thermal performance. A wide range of combustion characteristics and parameters can be determined by the flame emission spectrum[2].

In recent years, researches on measurement have focused on achieving more efficiencies, reducing combustion emissions and fuel consumption. These studies well address the challenges in the industry, which include increased efficiency, reliability, and flexibility[3].

In recent years, surface flame burners with low pollutant emission and high heat release have been considered. Soltanian et al. [4]in 2019, investigated a cylindrical surface burner. They presented the optimum operating range of the surface burner, considering the heat release rate factors. Fengguo Liu et al. [5]in 2020, investigated experimentally the performance of two types of burners in a condensing gas boiler. They stated when the excess air rate is in the range of 1.15 to 1.4, and the heat load is 24 kW, the CO emissions of the stainless-steel burner are higher than of the metal fiber burner. When the excess air rate is in the range of 1.15 to 1.4 and the heat load is 24 kW,  $\text{NO}_x$  emission of two burners will rise below 40 ppm at an excess air rate of 1.2.

The purpose of this study is to provide an approach to identify the performance and select the appropriate operating range of surface flame burner which used in condensing boilers. Performance parameters are equivalence ratio, heat release, stability, lift-off, and blow-off of the flame. Finally, the functional range is introduced.

## System description

A schematic diagram of the experimental apparatus is shown in Fig. 1. The air is supplied by a 0.75 kW side channel blower with an output pressure of 40 mbar – g.

The second line is for natural gas. Air-gas mixture enters the burner and ignites.

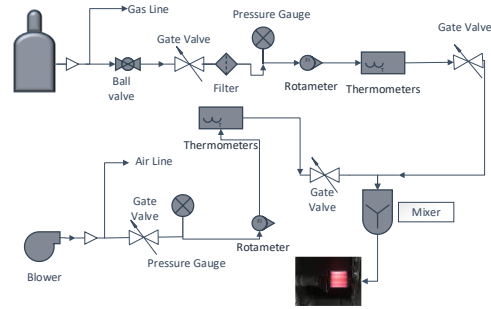

Fig 1- Schematic of the experimental apparatus

The schematic of the combustion chamber, the image analysis system, the chemiluminescence system and the gas analyzer are shown in Fig. 2.

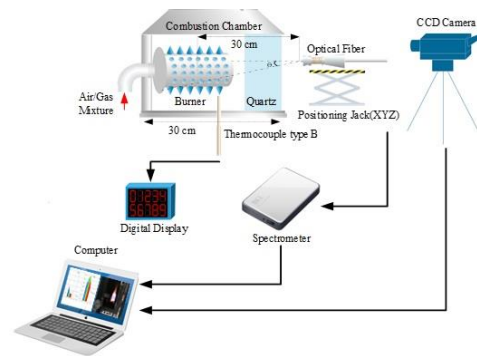

Fig 2- Schematic of the combustion chamber, CCD camera, and spectrometer

## Results and discussion

In this investigation, the natural flame spectrum and flame images are used as a tool to detect the performance parameters of a surface flame burner.

In previous studies, the intensity of hydroxyl radical radiation is an indicator of heat release. Fig. 3 shows the normalized variation of  $\text{OH}^*$ /power emission intensity versus equivalence ratio for operating burner powers. The maximum intensity of the  $\text{OH}^*$ /power is in the 0.8.

Fig. 4 shows  $\text{OH}^*$ /Power Curve fitting intensity variation for operating burner power versus equivalence ratio. The intensity increases with increasing burner power. In other words, heat release is increased with increasing fuel flow rate. It shows,  $\text{OH}^*$ /power intensity is an indicator of heat release. Chemiluminescence analysis can be used to specify the heat release trend and to calculate the equivalence ratio independent of the burner power.

In the present study, the stability of flame is defined as a blue flame in which no lift-off, flashback, and blow-off would occur[6]. According to the definition of stability, the blue flame is stable in the equivalence ratio that  $OH^*$  is maximum.

Fig. 5 depicts the functional diagram of the surface flame burner. The equivalence ratio limit for which a stable flame can be formed is obtained in the lean range for each burner power (stable flame zone). At equivalence ratios lower or higher than this range, the performance of the burner is not stable.

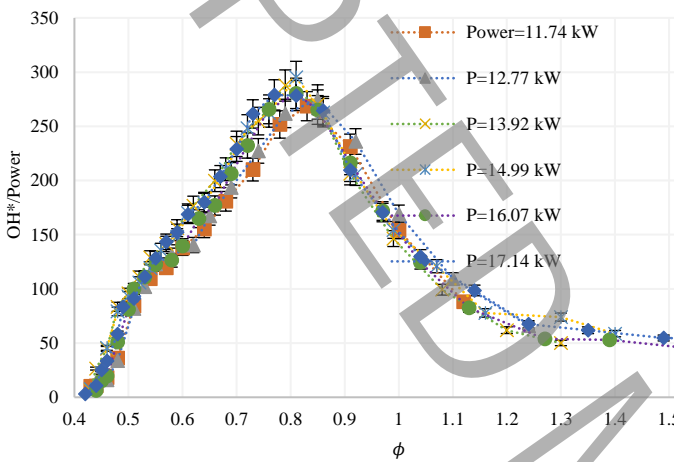

**Fig 3-  $OH^*$  / Power normalized intensity variation for operating burner power versus equivalence ratio**

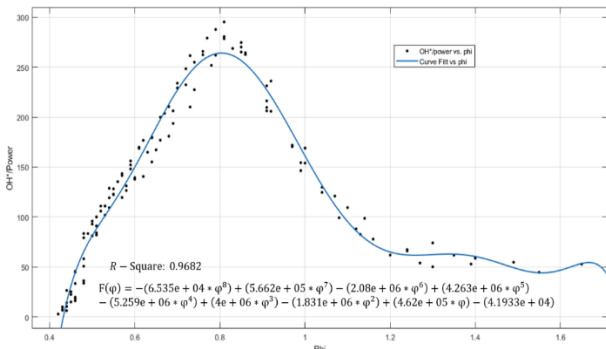
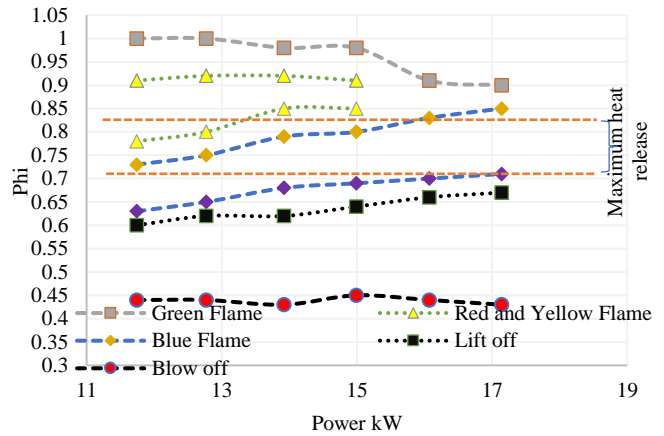

**Fig 4-  $OH^*$  / Power Curve fitting intensity variation for operating burner power versus equivalence ratio**

### Conclusions

The main conclusions of this study are as follows:

- Surface flame burners use flame-solid interaction to stabilize combustion and also to generate more heat in lean fuel conditions ( $\phi=0.8$  in this study).



**Fig 5- functional diagram for operating burner power versus equivalence ratio**

- Chemiluminescence analysis can be used to specify the heat release trend and to calculate the equivalence ratio independent of the burner power.
- A functional diagram imports the demand power to derive the equivalence ratio, ensures a stable high efficiency operation meeting the emission level limits.

### References

[1] M.M. Kamal, Two-line ( $CH^*/CO_2^*$ ) chemiluminescence technique for equivalence ratio mapping in turbulent stratified flames, *Energy*, 192 (2020).

[2] S.W. Yang, S.H. Lee, S.S. Hwang, Surface flame patterns and stability characteristics in a perforated cordierite burner for fuel reformers, *Proceedings of the Institution of Mechanical Engineers, Part A: Journal of Power and Energy*, 222(1) (2008) 25-30.

[3] P.H. Lee, S.S. Hwang, Formation of lean premixed surface flame using porous baffle plate and flame holder, *Journal of Thermal Science and Technology*, 8(1) (2013) 178-189.

[4] H. Soltanian, M.Z. Targhi, H. Pasdarsahri, Chemiluminescence usage in finding optimum operating range of multi-hole burners, *Energy*, 180 (2019) 398-404.

[5] F. Liu, L. Zheng, R. Zhang, Emissions and thermal efficiency for premixed burners in a condensing gas boiler, *Energy*, 202 (2020) 117449.

[6] S.R. Turns, *An introduction to combustion concepts and applications*, Third ed., McGraw-Hill, New York, 2012.