

Robust control of integrated reverse osmosis desalination system with photovoltaic power supply

Hossein Darvishnezhad, Mostafa Nazari*, Mohsen Nazari, Mohammad Mohsen Shah Mardan

Faculty of Mechanical and Mechatronics Engineering, Shahrood University of Technology, Shahrood, Iran

ABSTRACT

Among desalination systems, the use of reverse osmosis (RO) has become very widespread due to its advantages. One of the challenges in desalination systems especially in the reverse osmosis (RO) method is the existence of a control algorithm to overcome the uncertainties and disturbances. Another challenge of such systems is their power supply. A high-pressure pump supplies the pressure behind the membrane in the RO system. The use of renewable energy not only does not have any environmental effects but also provides sustainable energy for such systems. In this paper, to answer these two challenges, at first, the integrated model of the reverse osmosis desalination system with the solar photovoltaic system has been examined; then for each part, a control algorithm is designed and simulated. An optimized fuzzy controller has been designed to track the maximum power point at different temperatures and radiation conditions in the photovoltaic solar system. The fuzzy controller has been optimized with the invasive weed optimization algorithm (IWO). The electric motor has been controlled using a fuzzy PID algorithm. The super-twisting sliding mode control has been used for the RO system. The simulation results show that the proposed algorithm for the combined reverse osmosis-photovoltaic (RO-PV) system has a good performance in different operating conditions and can remove and eliminate disturbances on the system.

KEYWORDS

Desalination, Reverse osmosis, Super-twisting sliding mode control, Photovoltaic solar system, Maximum Power Point Tracking (MPPT), Fuzzy control

*Mostafa Nazari, nazari_mostafa@shahroodut.ac.ir

1. Introduction

The desalination process, which refers to the process of separating a special part of a water-soluble salt, is divided into two main categories: membrane-based methods and evaporation-based methods [1, 2]. The reverse osmosis (RO) desalination system, despite its high maintenance cost, has advantages such as simplicity in design, easy operation, and low energy consumption [3]. Membranes with lower water pressure behind them also perform better [1, 4]. In desalination systems, energy consumption is a very important factor.

Reverse osmosis systems require electricity to start their electric motor. Therefore, in places that do not have access to electricity, it is practically impossible to use such systems. In many parts of the world, people will be forced to move to another place due to the lack of electricity. Also, agriculture will practically disappear in such areas. Now, if the energy of this system can be supplied from available renewable energies [5, 6], it not only provides energy but also does not lead to environmental pollution. The most available renewable energy in Iran is solar energy. Therefore, in this paper, the energy supply of the reverse osmosis system is the photovoltaic system [7]. There are a lot of researches on controlling the reverse osmosis system, but most of these researches have focused on controlling the linear model of the reverse osmosis system. For example, the authors in [8, 9] have proposed an efficient closed-loop control strategy for industrial reverse osmosis desalination processes using traditional PID controllers. In [10], a controller has been designed and implemented on the reverse osmosis desalination laboratory system using geometric control methods based on a nonlinear model. The disadvantage of this research is that it does not include the necessary elements for the reverse osmosis system such as power supply, pumping process, and some others like them. There has been little research in this area to study a system that simultaneously includes a power source, pumping system, and reverse osmosis membrane, as well as control of each element of the system [10, 11]. In the present study, in addition to using a new super twisting sliding mode control strategy for the reverse osmosis system, a fuzzy optimal controller is designed to track the maximum power point in the photovoltaic system, and a fuzzy-PID controller [12] to control the motor-pump subsystem. These cases have not been investigated yet.

2. Components of reverse osmosis-photovoltaic combined system

The system structure is shown in Figure 1. In this configuration, we are looking for a system that can produce freshwater from various water sources using sustainable energy, so that it is economically and technically possible.

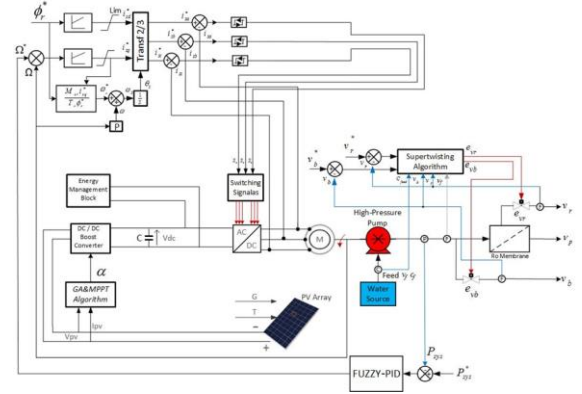

Figure 1. Combination of reverse osmosis desalination system and photovoltaic system

2.1. The Photovoltaic subsystem

The governing equations of the PV system are as follows:

$$I_{pv} = I_{ph} - I_0 \left(\exp \left(\frac{V_{pv} + (R_s I_s)}{v_t \alpha} \right) - 1 \right) - \frac{V_{pv} + (R_s I_s)}{R_{sh}} \quad (1)$$

$$v_t = \frac{N_s K T}{q} \quad (2)$$

$$I_{ph} = \left(I_{phref} + (K_{isc} (T - T_{ref})) \right) \frac{G}{G_{ref}} \quad (3)$$

$$I_{ph} = I_{phref} \left(\frac{T_{ref}}{T} \right)^3 \exp \left[\frac{q \cdot E_g}{\alpha \cdot K} \left(\frac{1}{T_n} - \frac{1}{T} \right) \right] \quad (4)$$

$$I_{0ref} = \frac{I_{scref}}{\exp \left(\frac{V_{ocref}}{V_{tref} \cdot \alpha} \right) - 1} \quad (5)$$

2.2. The RO subsystem

The governing equations of the RO system are as follows:

$$\begin{cases} \frac{d v_{vb}}{dt} = \frac{A_p^2}{A_m k_m v} (v_f - v_b - v_r) + \frac{A_p}{\rho V} \Delta \pi - \frac{1}{2} \frac{A_p e_{vb} v_b^2}{V} \\ \frac{d v_{vr}}{dt} = \frac{A_p^2}{A_m k_m v} (v_f - v_b - v_r) + \frac{A_p}{\rho V} \Delta \pi - \frac{1}{2} \frac{A_p e_{vr} v_b^2}{V} \end{cases} \quad (6)$$

2.3. Induction pump and motor subsystem

The speed loop control of the motor-pump sub-system is shown in Fig. 2.

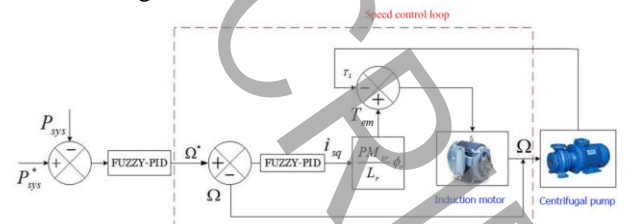

Figure 2. Motor-pump set with fuzzy PID control algorithm

The governing equations of the motor using field oriented control (FOC) are as follows:

$$\phi_{rd} = \phi_r \text{ and } \phi_{rq} = 0 \quad (15)$$

$$\frac{di_{sd}}{dt} = \frac{1}{\sigma L_s} \left(-\left(R_s + \left(\frac{L_m}{L_r}\right)^2 R_r\right) i_{sd} + \sigma L_s \omega_s i_{sq} + \frac{L_m R_r}{L_r^2} \phi_r + V_{sd} \right) \quad (16)$$

$$\frac{di_{sq}}{dt} = \frac{1}{\sigma L_s} \left(-\sigma L_s \omega_s i_{sq} - \left(R_s + \left(\frac{L_m}{L_r}\right)^2 R_r\right) i_{sq} - \frac{L_m}{L_r} \phi_r \omega_r + V_{sq} \right) \quad (17)$$

$$\frac{d\phi_{rd}}{dt} = \frac{L_m R_r}{L_r} i_{sd} - \frac{R_r}{L_r} \phi_r \quad (18)$$

3. Results and Discussion

In this paper, the reverse osmosis desalination system along with the solar photovoltaic system as an energy supplier is investigated. To maximum power tracking, an optimized fuzzy controller optimized with invasive grass algorithm (IGA) has been used.

A fuzzy-PID controller is used to control the motor speed as well as the pressure behind the membrane; and to control the discharges in the reverse osmosis system, the super twisting sliding mode control has been used. The implemented controllers can eliminate disturbances caused by temperature changes and water salinity changes. For this purpose, the controller performance was evaluated in salinities with 100%, 200% and 300% increase (Fig. 3).

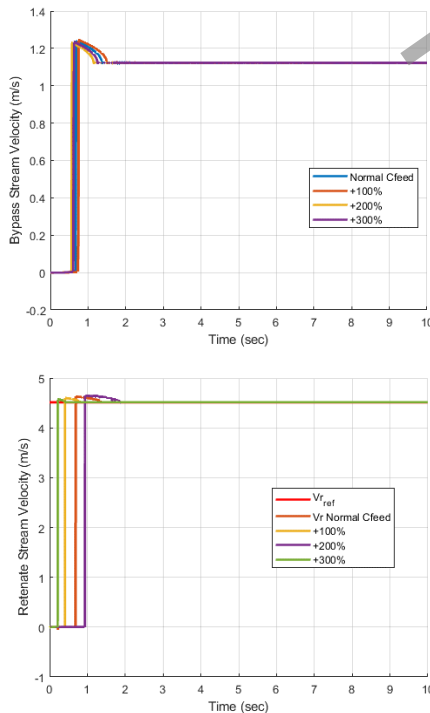

Figure 3.The performance of the super twisting sliding model controller in dealing with disturbances in water salinity

4. Conclusion

In this paper, the combined photovoltaic-reverse osmosis (PV-RO) desalination system has been considered, and for each part of the system a controller has been designed. The simulation results show that the proposed controllers not only perform well but also are robust in changing conditions such as inlet water concentration and rotor resistance. Therefore, the designed controllers can be used to build a reverse osmosis system with stable performance using renewable energy.

5. References

- [1] S. Sobana, R.C. Panda, Modeling and control of reverse osmosis desalination process using centralized and decentralized techniques, *Desalination*, 344 (2014) 243-251.
- [2] L.F. Greenlee, D.F. Lawler, B.D. Freeman, B. Marrot, P. Moulin, Reverse osmosis desalination: water sources, technology, and today's challenges, *Water research*, 43(9) (2009) 2317-2348.
- [3] T. Zhao, R. Niu, M. Su, T. Anderson, Steady state and dynamic modeling of RO desalination modules and system using EES, in: 2011 IEEE International Conference on Robotics and Automation, IEEE, 2011, pp. 1-4.
- [4] Y.-Y. Lu, Y.-D. Hu, X.-L. Zhang, L.-Y. Wu, Q.-Z. Liu, Optimum design of reverse osmosis system under different feed concentration and product specification, *Journal of membrane science*, 287(2) (2007) 219-229.
- [5] H. Sharon, K. Reddy, A review of solar energy driven desalination technologies, *Renewable and Sustainable Energy Reviews*, 41 (2015) 1080-1118.
- [6] A.M. Bilton, L.C. Kelley, S. Dubowsky, Photovoltaic reverse osmosis—Feasibility and a pathway to develop technology, *Desalination and Water Treatment*, 31(1-3) (2011) 24-34.
- [7] E. Tzen, R. Morris, Renewable energy sources for desalination, *Solar energy*, 75(5) (2003) 375-379.
- [8] I. Alatiqi, H. Ettouney, H. El-Dessouky, Process control in water desalination industry: an overview, *Desalination*, 126(1-3) (1999) 15-32.
- [9] I. Alatiqi, A. Ghabris, S. Ebrahim, System identification and control of reverse osmosis desalination, *Desalination*, 75 (1989) 119-140.
- [10] A.R. Bartman, P.D. Christofides, Y. Cohen, Nonlinear model-based control of an experimental reverse-osmosis water desalination system, *Industrial & Engineering Chemistry Research*, 48(13) (2009) 6126-6136.
- [11] M. Zebbar, Y. Messlem, A. Gouichiche, M. Tadjine, Super-twisting sliding mode control and robust loop shaping design of RO desalination process powered by PV generator, *Desalination*, 458 (2019) 122-135.
- [12] Z.-Y. Zhao, M. Tomizuka, S. Isaka, Fuzzy gain scheduling of PID controllers, *IEEE transactions on systems, man, and cybernetics*, 23(5) (1993) 1392-1398.