



Employing of shunt damping method to reduce edgewise vibration of small size wind turbine blade with considering the effect of vibration coupling

H. Biglari, V. Fakhari*

Faculty of Mechanical and Energy Engineering, Shahid Beheshti University, Tehran, Iran

ABSTRACT: In this paper, the vibration reduction of a small-scale horizontal axis wind turbine blade is investigated using the shunt damping method by considering the coupling between edgewise and flapwise vibrations. First, the nonlinear differential equations governing the blade dynamics with shunt damper are derived using the Lagrange method. Then, by performing the sensitivity analysis and selecting the appropriate cost function and constraints, the shunt damper parameters are optimized using the genetic algorithm method for a real blade. It should be noted that in this study, the wind force applied to the blade is considered sinusoidal with variable frequency at four different speeds. After solving the governing dynamic equations, to evaluate the effectiveness of the mentioned method in reducing vibrations, the obtained results in this study are compared with the corresponding results of employing the optimized tuned mass damper for suppression of edgewise vibrations of the blade. Results show that the tuned mass damper and shunt damping method have good effects on reducing vibrations. Despite that, the tuned mass damper effect on vibration reduction at high wind speeds is greater than the shunt damping method, at low wind speeds, the shunt damping has a greater effect on reducing vibrations.

Review History:

Received: Jan. 12, 2020
Revised: Apr. 01, 2020
Accepted: Jun. 20, 2020
Available Online: Jul. 22, 2020

Keywords:

Wind turbine blade
Edgewise vibration reduction
Shunt damping
Optimization
Vibration coupling

1- Introduction

Shunt damping is one of the methods to reduce vibrations. This method is based on adding damping to the system and converting unwanted vibrational energy into thermal energy [1]. Biglari and Fakhari [2] considered a relatively complete model for wind turbine blades, taking into account the coupling effects of edgewise vibrations and flapwise vibrations, as well as gravity and centrifugal forces. Based on this model, they investigated reduced edgewise vibrations of the small-scale wind turbine blade. Also, in another research, the authors of this paper, proposed the shunt damping method to reduce the edgewise vibrations of the small-scale wind turbine blade and evaluated its effectiveness by providing appropriate simulations. The results indicate the appropriate efficiency of this method in reducing blade vibrations [3]. But, in that study, the effect of the coupling between edgewise and flapwise vibrations was ignored for simplification in blade modeling.

In this paper, the reduction of small-scale wind turbine blade vibrations is evaluated using the shunt damping method by considering the relatively complete vibration model of blades including the coupling between edgewise and flapwise vibrations. Although, considering vibration couplings makes equations of motion more complex, but this will lead to a more accurate dynamic model of the blade.

2- Dynamic Model of Wind Turbine Blade

Fig. 1 shows a view of the wind turbine blades with the corresponding coordinate system. Fig. 2 indicates the

packaging of the piezoelectric layers in the wind turbine blade along with its related coordinates

The final vibration equations of the blade with shunt damping are obtained using the Lagrange method as follows:

$$\begin{aligned} & \left(m_{in} + \left[m_{plate} + \sum_{i=1}^n 2m_{piezo} \right] \varphi_{in}^2(x_{z_i}) \right) \ddot{q}_{in} + \\ & \sum_{i=1}^n 2m_{piezo} \varphi_{in}(x_{z_i}) \ddot{q}_p + c_{in} \dot{q}_{in} \\ & + \left(k_{in} + k_{in_plate} + 2\alpha \right. \\ & \left. - \left(\left[m_{in} + m_{plate} + \sum_{i=1}^n 2m_{piezo} \right] \varphi_{in}^2(x_{z_i}) \right) \Omega^2 \right) q_{in} \\ & - 2\beta q_p + (k_c + k_{c_plate}) q_{out} = f_{in} \\ & + g \sin \Psi_j \int_0^L \mu(x_3) \varphi_{in}(x_3) dx_3 + \\ & g \sin \Psi_j \left[m_{plate} + \sum_{i=1}^n 2m_{piezo} \right] \varphi_{in}^2(x_{z_i}) \end{aligned} \quad (1)$$

*Corresponding author's email: v_fakhari@sbu.ac.ir



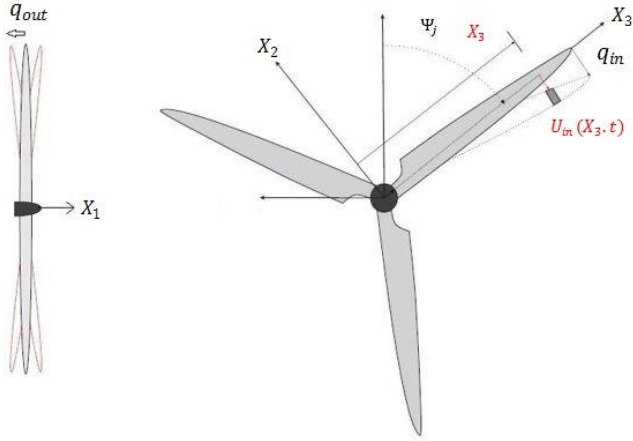

Fig. 1. Wind turbine blade and the related coordinates in edgewise and flapwise vibrations [2]

$$\begin{aligned} & \left(m_{out} + \left[m_{plate} + \sum_{i=1}^n 2m_{piezo} \right] \varphi_{out}^2(x_{z_i}) \right) \ddot{q}_{out} \\ & + c_{out} \dot{q}_{out} + (k_{out} + k_{out_plate}) q_{out} \\ & + (k_c + k_{c_plate}) q_{in} = f_{out} \end{aligned} \quad (2)$$

$$\begin{aligned} & \left(\sum_{i=1}^n 2m_{piezo} + \sum_{i=1}^n \sum_{i=1}^n 4L \right) \ddot{q}_p + \\ & \left(\sum_{i=1}^n 2m_{piezo} \varphi_{in}(x_{z_i}) \right) \ddot{q}_{in} \\ & + \left(\sum_{i=1}^n \sum_{i=1}^n 4R \right) \dot{q}_p + 2\gamma q_p - 2\beta q_{in} = 0 \end{aligned} \quad (3)$$

Then, by performing the sensitivity analysis and selecting the appropriate cost function and constraints, the shunt damper parameters are optimized using the genetic algorithm method for a real blade. The objective function of the optimization problem is considered as a combination of the maximum displacement at the end of the blade and the total mass of the piezoelectric, which optimization tries to reduce this objective function.

3- Results and Discussion

By considering the wind excitation as a sweep sine wave (from 30 up to 250 rad/s), simulations were performed for four different average wind speeds. The simulation result in the wind speed of 15 m/s is shown in Fig. 3.

To observe the effectiveness of the shunt damping method in reducing vibrations, a comparison between the root mean square (rms) of the edgewise vibration of the blade with a shunt damper and tuned mass damper is made. This comparison is shown in Table 1.

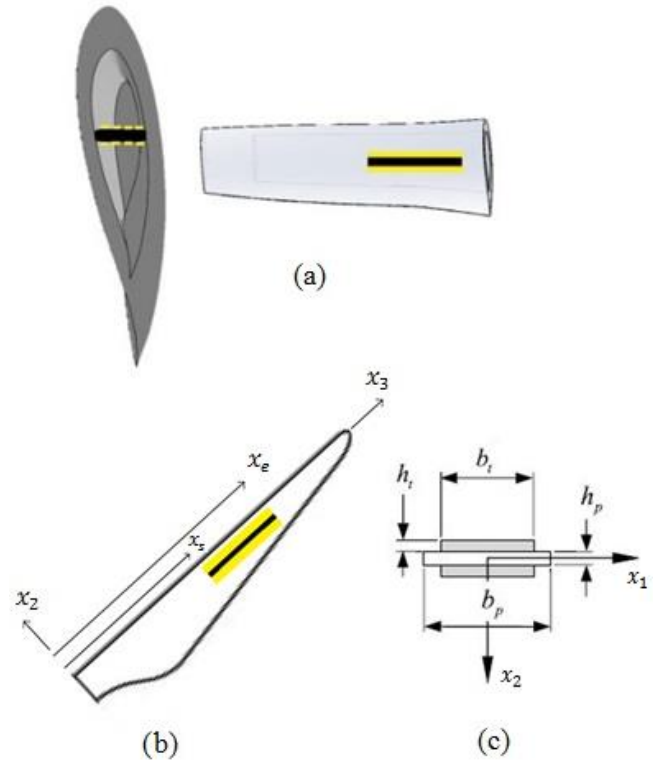

Fig. 2. Packaging of the plate and piezoelectric layers in the wind turbine blade with the relevant coordinates [3]

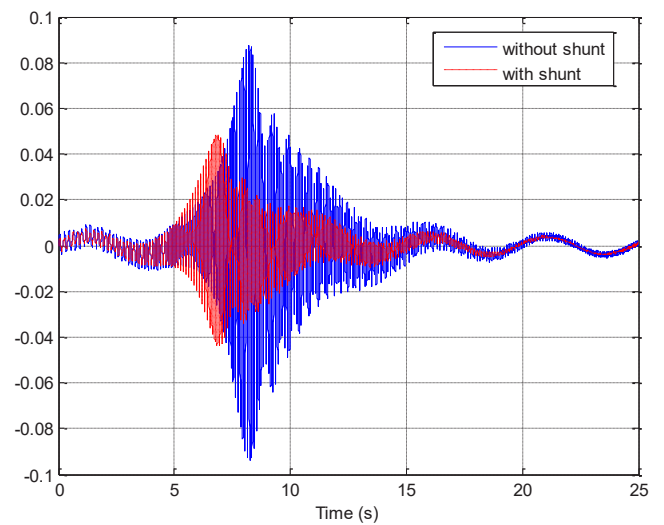

Fig. 3. Edgewise vibration of the wind turbine blade with and without the optimal shunt damper in the presence of a sweep sine excitation for the wind average speed of 15 m/s

Table 1. Effect of the shunt and tuned mass dampers in suppression of the rms edgewise vibration at the tip of the wind turbine blade in the presence of a sweep sine excitation from 30 to 250 rad/s

Wind speed	Percentage of suppression in rms edgewise vibrations at the tip of the blade with shunt damper	Percentage of suppression in rms edgewise vibrations at the tip of the blade with tuned mass damper [2]
5 m/s	30	11
10 m/s	44	40
15 m/s	46	49
20 m/s	51	54

4- Conclusions

In this study, the shunt damping method was employed to reduce edgewise vibrations of the wind turbine blade by considering the effect of the vibration coupling. In order to investigate the effectiveness of the shunt damping method in reducing edgewise vibrations, the shunt damping method was compared with one of the conventional methods, namely, tuned mass damping. The obtained results show that both methods have considerable effects on reducing vibrations. However, the tuned mass damper effect on vibration reduction at high wind speeds is greater than the shunt damping method. In addition, at low wind speeds, the shunt damping has a greater effect on reducing vibrations.

References

- [1] D.E. Casagrande, Piezoelectric transducers for broadband vibration control, PhD Thesis, University of Udine, 2016.
- [2] H. Biglari, V. Fakhari, Edgewise Vibration Reduction of a Small-Scale Wind Turbine Blade with Considering Vibration Coupling, *Amirkabir Journal of Mechanical Engineering*, 52(8) (2020) 151-160. (in Persian)
- [3] H. Biglari, V. Fakhari, Edgewise vibration reduction of small size wind turbine blades using shunt damping, *Journal of Vibration and Control*, 26(3-4) (2020) 186-199.

HOW TO CITE THIS ARTICLE

H. Biglari, V. Fakhari, *Employing of shunt damping method to reduce edgewise vibration of small size wind turbine blade with considering the effect of vibration coupling*, *Amirkabir J. Mech. Eng.*, 53(4) (2021) 495-498.

DOI: [10.22060/mej.2020.17717.6652](https://doi.org/10.22060/mej.2020.17717.6652)



